

**LIFTING AND
TRANSPORT EQUIPMENT**

2026

2027

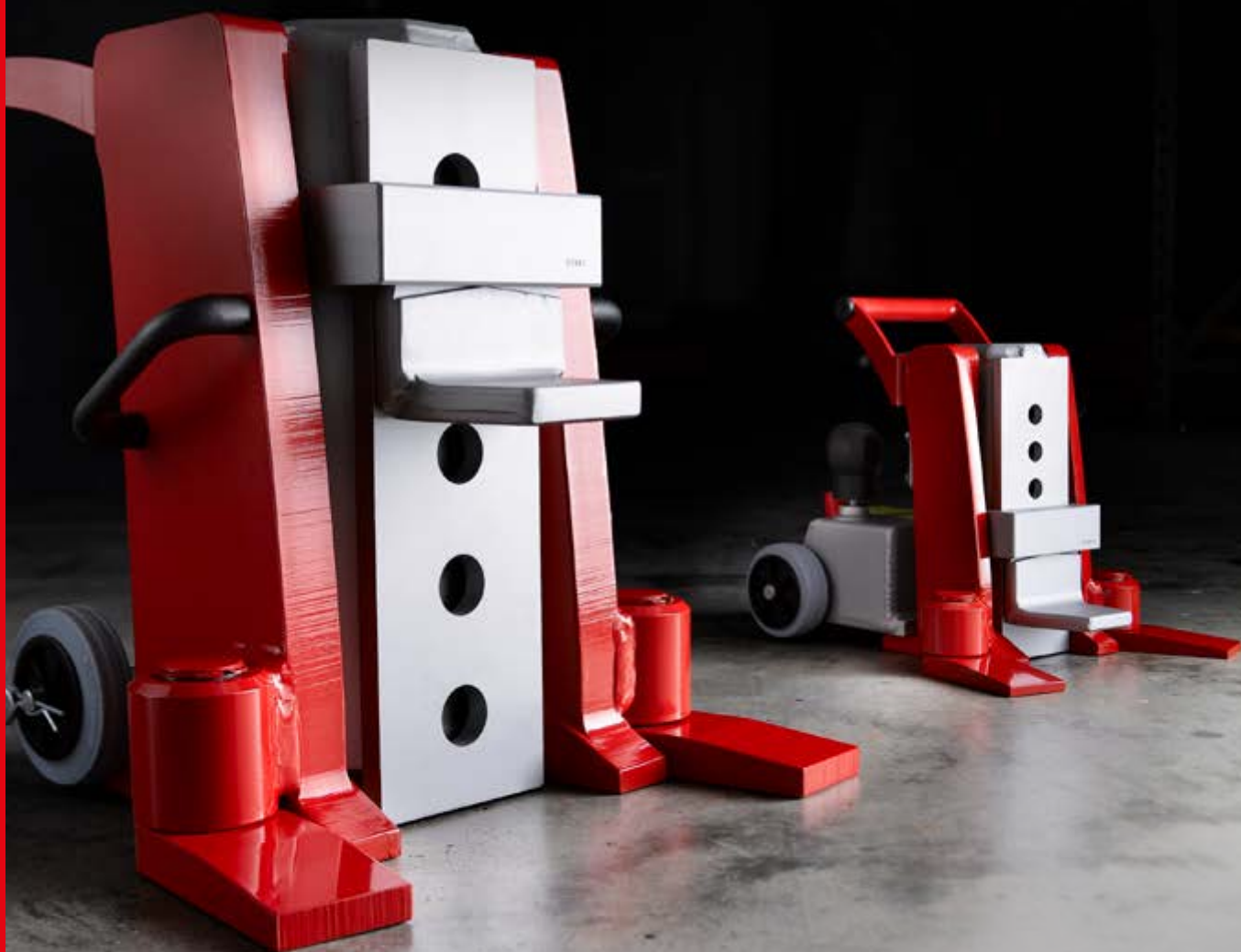

JUNG
●●●
JUNG-HEBETECHNIK.DE

JUST MOV

E SAFELY.

Our aim is to make lifting and moving heavy loads easier, safer and more ergonomic for the user.

JUNG

WE MAKE A DIFFERENCE. TONS OF IT.



DIN EN ISO 9001
REG.-NR. Q1 0206008



UNTERNEHMEN
MACHEN KLIMASCHUTZ



MADE IN GERMANY

We have over 50 years of experience in the development and manufacture of rigging equipment.

Our lifting and transport equipment has proven itself thousands of times as essential tools in all areas in which the movement of heavy loads is required.

WARRANTY

We provide a 5-year warranty on all jacks and transport trolleys when products are used as directed – except for JLA-e, where we provide a 1 year warranty or 1000 operating hours.

QUALITY

You can always trust in the quality and durability of our products. To manufacture highest quality we use most modern machines and assure a continuously high standard by a certified quality management system.

State of the art CNC technology, advanced welding robots and a certified quality management system (DIN EN ISO 9001) assure a consistently high level of product quality. Each hydraulic jack is subjected to a pre-shipment function test and receives a test badge displaying the next recommended maintenance check date. Each self-powered trolley is also subjected to a pre-shipment function test.

Following products are ANSI/ASME (USA) tested: JH G-plus, JH G-plus EX, JHS, JKB, series K and M, series G.



AVAILABILITY

As a rule, we have extensive stock for a large number of our series products. In most cases, the products are therefore available within a short time.

PROCESSES & ENVIRONMENT

As an ISO 9001 certified company we continuously improve our processes by involving our customers, employees and suppliers.

REPAIR & MAINTENANCE SERVICE

Even after many years of usage, our products are still ready for use. To achieve this we provide maintenance and repair service, as well as replacement parts.



SOME STATIONS.

JUNG on the move.



1972

FOUNDING

Karl-Heinz Jung founds the company JUNG in Kernlen near Stuttgart.

1982

FIRST COMPANY BUILDING

The first own company building is built at the current location in Waiblingen.

1993

OWN SALES

JUNG separates from former exclusive distribution partner and builds up its own sales dep.

2003

FOOT MASTER®

JUNG starts selling FOOT MASTER® leveling castors.

2002

TUGGER TRAIN

JUNG expands its product range and now also produces trailers for in-house logistics.

2001

NEW BUILDING

JUNG doubles the production area by building a new hall at the Waiblingen site.

2008

INDUSTRIAL HYDRAULICS

JUNG is again expanding its product range to include industrial hydraulics.

2009

EXPANSION

JUNG further expands the production area by another hall at the Waiblingen site.

2014

NEW PRODUCT LINE

JUNG presents the first electric-powered trolley JLA-e 15/30 G.

2020

SUPPORT TECHNOLOGY

Expansion of the product range with support technology and surface protection

2017

GORR TRANSPORTTECHNIK

JUNG acquires the company Gorr Transporttechnik GmbH in Eschwege.

2017

LIFTING BAGS

JUNG starts the distribution of lifting bags.

2024

TRANSPORT PLATFORMS

JUNG launches the exclusive distribution of Eyher transport platforms in Germany.

2025

NEW BUILDING

JUNG is moving into the new building at Biegelwiesenstrasse 22. The existing buildings will continue to be used.



In several stages, JUNG was expanded from a one-man operation to an international company. In the meantime JUNG has more than 65 employees. Many of them have been with the company for a long time, in some cases even completed their training at JUNG. Our employees have the goal of working together to achieve the best for our customers.

Our ambition for over 50 years is to make lifting and moving heavy loads easier, safer and more ergonomic for the user. According to our slogan: JUNG = Innovation, Karl-Heinz Jung and Thomas Würthele, together with the JUNG employees, have developed a large number of different devices to be able to offer the right product for every application.

LIST OF CONTENT

JACKS	12
Series JH-G plus – jacks for loads up to 20 metric tons	14
Series JH-G plus EX – jacks for loads up to 30 metric tons	16
Electrical pumps JPE	17
Series JHS – jack sets for loads up to 20 metric tons	18
Hand pump JP and air hydraulic pump JPL	20
Useful accessories for jacks and hydraulic hoses JS	21
Hydraulic pressure blocks JD	22
TROLLEY INFORMATION AND OVERVIEW	24
Series K – transport trolleys for loads up to 24 metric tons	26
Series K professional – transport trolleys for loads up to 28 metric tons	28
Series S – transport trolleys for loads up to 48 metric tons	30
Series G professional – tandem transport trolleys for loads up to 60 metric tons	32
Series H professional – transport trolleys for loads up to 200 metric tons	34
TANDEM TRANSPORT TROLLEYS	36
Series K – tandem transport trolleys for loads up to 14 metric tons	38
Series G – tandem transport trolleys for loads up to 60 metric tons	39
Tandem transport „Weld-on Cone“ transport of containers up to 28 metric tons	40
Tandem transport Twistlock transport of containers up to 60 metric tons	41
Container-Traverse – for loads up to 36 metric tons	42
MULTI-PURPOSE TROLLEYS	44
Series M – multi-purpose trolley for loads up to 15 metric tons	46
REVOLVING TRANSPORT TROLLEYS	48
Series JKB – revolving transport trolleys for loads up to 28 metric tons	50
USEFUL ACCESSORIES	54
STURDY CASTORS FOR ANY APPLICATION	56
ELECTRIC-POWERED TROLLEYS	58
JLA-e electric-powered trolleys – for loads up to 50 metric tons	60
JLA-e trolley configurations	62
JLA-e trolleys with stroke electric-powered – for loads up to 30 metric tons	64
Useful accessories for electric-powered trolleys	66
JLA-e trolley air-powered – for loads up to 30 metric tons	68
JLA-e trolley SETs air-powered	69
ELECTRIC POWERED TRANSPORT TROLLEYS IN FORMATION	70
JLA-eFORM, Electric powered transport trolleys in formation – for loads up to 45 metric tons	72
ACCESSORIES FOR FORKLIFTS	74
HYDRO-TRANSPORTER	76
Hydro-Transporter – for loads up to 3,8 metric tons	77
OPTIONAL NICKEL-PLATED EQUIPMENT AND CUSTOM SOLUTIONS	78

Professional solutions. For professionals.

PATENTED

Work and lift safely with our patented lifting toe system (Pat.-No. 4413478).

SAVE WEIGHT

Extreme weight reduction by improved construction.

FLEXIBLE

Removable handle on JH 6 G plus and JH 10 G plus.

EXPANDABLE

Custom-made upon request, available with side handles and/or a standard handle.

SECURE AND TEAR RESISTANT

Swiveling safety toe made from dieforged steel for extreme robustness that prevents fractures. The advanced strength steel is impact resistant and provides optimal safety.

LOW COST

Easy maintenance by single removable pump unit; safety pressure relief valve with dirt filter prevents overloading. Also available without integrated pump unit. See JH G plus series EX version.

RELIABLE STURDY

Sturdy, 180° swivelling feet – for easy and safe positioning in every situation.

MAXIMUM OUTPUT

Maximum output due to reduced friction in the lifting track with our patented slide shoe design.

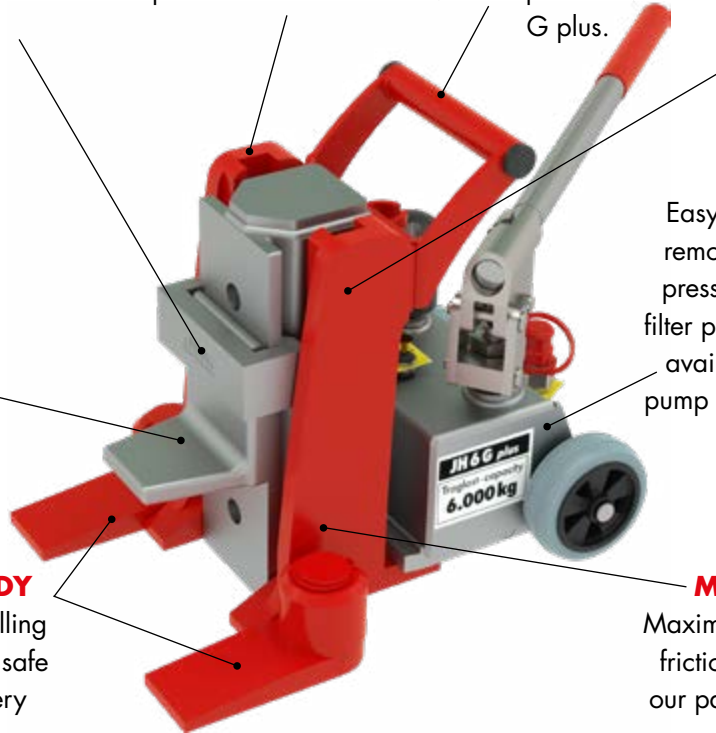

Swiveling lifting toe for safe and optimal adjustment to loads on varying inclines up to +6°.

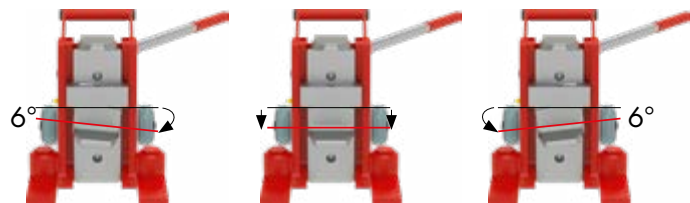

- J** — Jack (p. 14-16)
- HS** — Hydraulic jack (p. 18-19)
- D** — Pressure Block (p. 22-23)
- P** — Pump (p. 20)
- PL** — Pump Air Hydraulic (p. 20)
- PE** — Pump Electrical (p. 17)

6 — Capacity in [metric tons]

- G PLUS SERIE** — slide shoe-system (p. 14-16)
- E+VS** — Electrical + Valve control (p. 22-23)
- NVR** — Needle valve with return (p. 17)

- EX** — External Pump (p. 16)
- KU** — Short Jack (p. 14)

TRANSPORT-TROLLEYS

i Technical drawings of the respective devices can be found at jung-hebetechnik.de

Move safely.

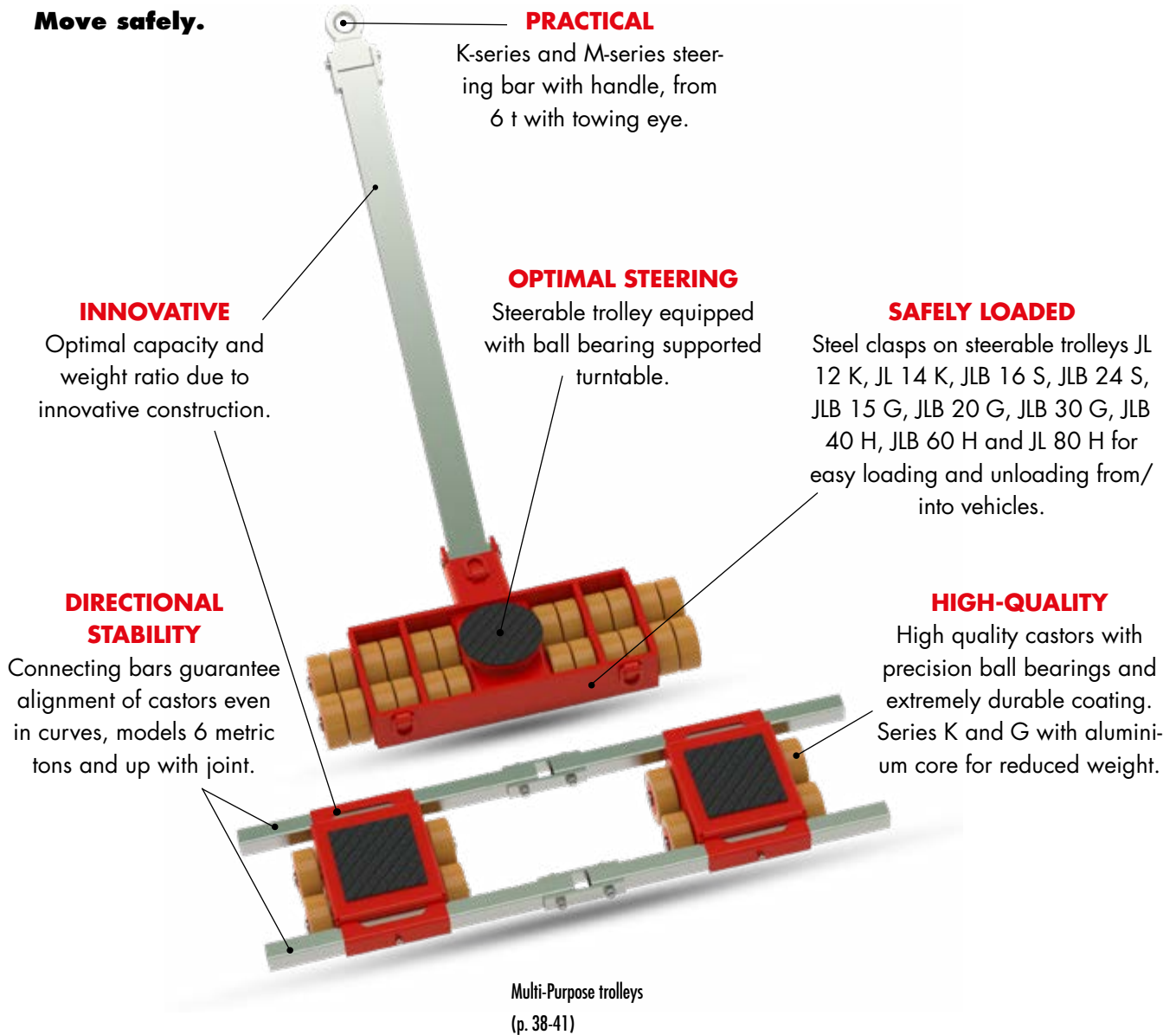

PRACTICAL

K-series and M-series steering bar with handle, from 6 t with towing eye.

INNOVATIVE

Optimal capacity and weight ratio due to innovative construction.

OPTIMAL STEERING

Steerable trolley equipped with ball bearing supported turntable.

SAFELY LOADED

Steel clasps on steerable trolleys JL 12 K, JL 14 K, JLB 16 S, JLB 24 S, JLB 15 G, JLB 20 G, JLB 30 G, JLB 40 H, JLB 60 H and JL 80 H for easy loading and unloading from/into vehicles.

DIRECTIONAL STABILITY

Connecting bars guarantee alignment of castors even in curves, models 6 metric tons and up with joint.

HIGH-QUALITY

High quality castors with precision ball bearings and extremely durable coating. Series K and G with aluminum core for reduced weight.

Multi-Purpose trolleys (p. 38-41)

- J** — High quality products
- L** — Steerable
- F** — Straight-line
- LF** — Multi-Purpose trolleys (p. 38-41)
- TL** — Tandem transport trolley (p. 46-47)
- K** — Revolving transport trolley (p. 50-53)
- B** — Bending construction
- A** — Driven
- e** — Electrical (p. 60-65)
- p** — Pneumatic (p. 68-69)
- 3** — Capacity in metric tons
- K** — For load weight up to 24 metric tons, Height: 110 mm (p. 26-27)
- K** — Professional — For load weight up to 28 metric tons, Height: 110 mm (p. 28-29)
- S** — For load weight up to 48 metric tons, Height: 125 mm (p. 30)
- G** — Professional — For load weight up to 60 metric tons, Height: 180 mm (p. 32-33)
- H** — Professional — For load weight up to 200 metric tons, Height: 230/240 mm (p. 34-35)
- M** — For load weight up to 15 metric tons, Height: 150 mm (p. 46-47)

RESPONSIBILITY AWARENESS.



CUSTOMER

The satisfaction of our customers is in the center of our efforts. Due to our creativity and our expertise, we realize individual customer requests.

STAFF

The company's success is depending on our staff members. Therefore, we are continuously investing in training and development and support the experience and competence through long-term employment.



SOCIAL COMMITMENT

We are a part of Waiblingen and are glad to support regional social and charitable organizations.

ENVIRONMENT

We meet our ecological responsibilities in our daily work flow. We utilize our own solar power, obtain power from regenerative energy sources and have examined our ecological accountability under the Ecofit project.

LIFT **SAFELY.**

Easy. Handy. Strong.



JUNG
L O O L

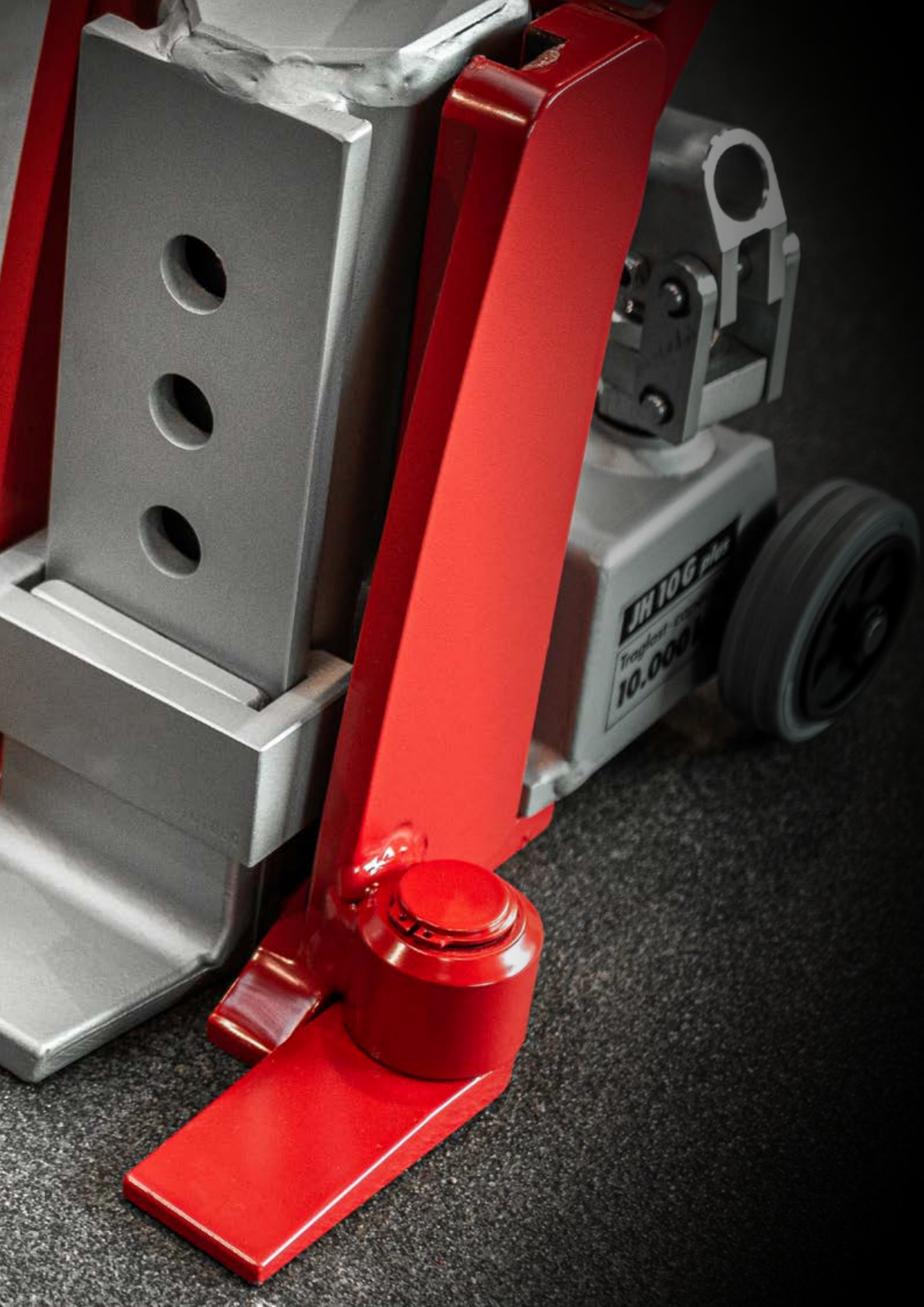

JACKS

SERIES JH-G PLUS



With integrated pump unit, for loads up to 20 metric tons

i DESCRIPTION

- JH 15/JH 20 G plus serial outfitted with fast stroke. Also available with spring return.
- Reduced maintenance costs due to easily replaceable slide shoes and a removable pump unit.
- Continuous adjustment to the load due to swiveling safety toe. Secure and stable in every situation, even in lifted position (see picture 1).

- Extremely lightweight with high performance due to the use of high quality material and innovative design.
- Die-forged steel toe provides impact resistance.
- Safe operation due to ergonomic lowering screw.

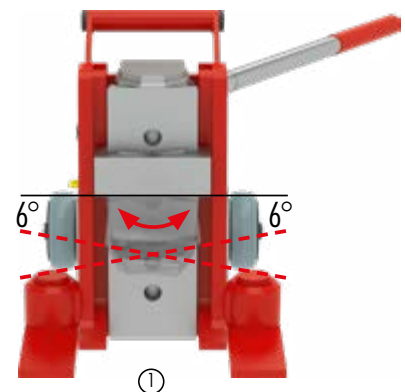

TYPE		JH 6 G PLUS	JH 10 G PLUS	JH 10 G PLUS KU
Load capacity on top plate	kg	6 000	10 000	10 000
Stroke	mm	140	150	108
Minimum lift toe height	h 1 mm	12	15	15
Maximum lift toe height	h 2 mm	157	180	138
Lift toe adjustment	V mm	6 x 29	5 x 41	4 x 41
Top plate height	H 1 mm	245	275	233
Toe width front	L b mm	50	60	60
Toe depth	n L mm	50	55	55
Length feet in front	L 2 mm	326	346	346
Length feet on side	L 1 mm	311	330	330
Width	B mm	233	247	247
Height	H 2 mm	280	310	233
Cylinder volume	Liter	0,18	0,3	0,21
Weight	kg	22	29	28

ORDER NO.	01 060 102-G	01 100 102-G	01 100 103-G KU
-----------	--------------	--------------	-----------------



JH 15 G plus in use combined with our JL 9 K



Custom orders available upon request:

Left: JH 6 G plus with standard handle and side handles

Right: JH 10 G plus with side handles, without standard handle

NEW SLIDE SHOE DESIGN

- More power on the lift toe.
- By optimizing materials, resource consumption is effectively reduced.
- The optimized geometry results in reduced tilting moments and increased stability.
- The simplified/reduced component design reduces the maintenance required.
- Less labour required for the same load due to reduced friction.

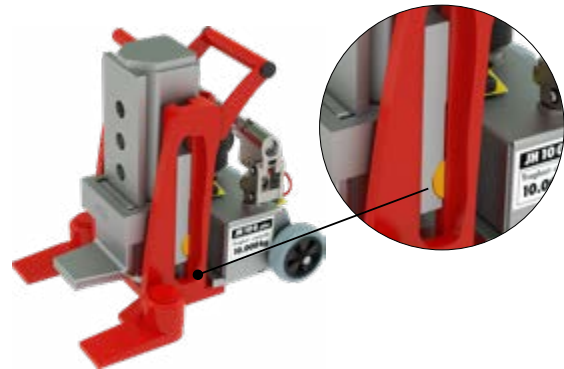

TYPE		■ JH 15 G PLUS		■ JH 20 G PLUS	
Load capacity on top plate		kg	15 000		20 000
Stroke		mm	175		190
Minimum lift toe height	h 1	mm	20		20
Maximum lift toe height	h 2	mm	205		225
Lift toe adjustment	V	mm	5 x 46		5 x 51
Top plate height	H 1	mm	310		340
Toe width front	L b	mm	80		80
Toe depth	n L	mm	64		64
Length feet in front	L 2	mm	415		425
Length feet on side	L 1	mm	393		405
Width	B	mm	322		322
Height	H 2	mm	310		340
Cylinder volume		Liter	0,5		0,73
Weight		kg	48		60
ORDER NO.			■ 01 150 102-G		■ 01 200 102-G

JACKS

SERIES JH-G PLUS EX



Without integrated pump unit, for loads up to 30 metric tons

i DESCRIPTION

■ Integrated spring return retracts piston automatically (see picture 1) on JH 15 up to JH 30 G plus Ex.

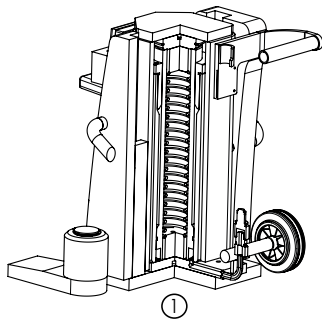

■ Extremely lightweight with high performance due to the use of high-quality material and innovative design.

■ Continuous adjustment to the load due to swiveling safety toe. Secure stability in every situation even in lifted position (see picture 2).

■ Reduced maintenance costs due to removable stroke unit and easily replaceable slide shoes.

■ **New slide shoe design*** (see Page 15)

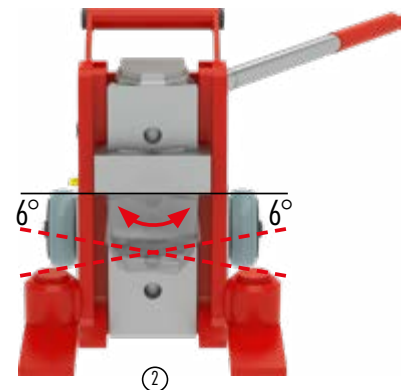

*Does not apply to JH 30 G Plus EX

External pump necessary. Please refer to page 17 for electrical pumps, page 20 for hand pumps, for hydraulic hoses to page 21.



TYPE			JH 10 G PLUS EX	JH 15 G PLUS EX	JH 20 G PLUS EX	JH 30 G PLUS EX
Load capacity on top plate		kg	10 000	15 000	20 000	30 000
Stroke		mm	150	175	190	200
Minimum lift toe height	h 1	mm	15	20	20	20
Maximum lift toe height	h 2	mm	180	205	225	304
Lift toe adjustment	V	mm	5 x 41	5 x 46	5 x 51	5 x 71
Top plate height	H 1	mm	275	310	340	420
Toe width front	L b	mm	60	80	80	80
Toe depth	n L	mm	55	64	64	64
Length feet in front	L 2	mm	270	340	360	380
Length feet on side	L 1	mm	251	230	330	370
Width	B	mm	247	300	322	375
Height	H 2	mm	308	310	340	420
Cylinder volume		Liter	0,3	0,5	0,73	1,27
Weight		kg	29	42	55	95

Order No. **11 610 106-G** **11 615 106-G** **11 620 106-G** **11 630 106-G**

ELECTRICAL PUMPS

JPE

Powerful and quick

See pages 14-19 for suitable jacks and page 21 for hydraulic hoses.



i DESCRIPTION

- Quick connectors with drip free rapid closure valves.
- One oil circuit capable of supplying two or four hydraulic jacks.
- **Easily controllable:** JPE 30-NVR with precision lowering regulator.
- Sturdy two stage electric pumps available in different versions.



Electric pump JPE 30/4 NVR with 4 jacks in operation.

- Easy handling.
- Includes transport cart for easy and safe transport (JPE 30NVR).
- Also available as 110 V, 50 Hz.
- Maximum safety during operation due to cable remote control.

SUITABLE JACKS FOR FÜR ELECTRICAL PUMPS*

JACKS	JPE 20/2	JPE 30 NVR
JH 6 G plus	1 to 2	1 to 4
JH 10 G plus / G plus ku / G plus EX	1 to 2	1 to 4
JH 15 G plus / G plus EX	1 to 2	1 to 4
JH 20 G plus / G plus EX	1 to 2	1 to 2
JH 30 G plus EX	1 to 2	1
JHS 5	1 to 2	1 to 4
JHS 10	1 to 2	1 to 4
JHS 10 ku	1 to 2	1 to 4

*More Information can be found at jung-hebetechnik.de.

JPE30 NVR

Standard version
Equipped with 2 hydraulic connections with precise adjustable needle valves and 1 manometer.

JPE30/4 NVR

Extended version
Equipped with 4 hydraulic connections, each equipped with precise adjustable needle valves and 1 manometer.



ELECTRICAL PUMPS WITHOUT HOSES

TYPE		JPE 20/2	JPE 30 NVR	JPE 30/4 NVR
Oil volume complete/usable	L	5/3,7	7,6/4,8	7,6/4,8
Working pressure	bar	520	520	520
Connections	pcs.	2	2	4
Flow rate low pressure	L/min.	2,5 - 7 bar	3,9 - 7 bar	3,9 - 7 bar
Flow rate high pressure	L/min.	0,45 - 520 bar	0,33 - 520 bar	0,33 - 520 bar
Motor facts		230 V, 50 Hz, 5 A	230 V, 50 Hz, 5 A	230 V, 50 Hz, 5 A
Dimensions L x W x H*	mm	420 x 205 x 300	680*(900**) x 330 x 600	680*(900**) x 330 x 600
Total weight with oil	kg	18	38	41
Usable jacks		any hydraulic jacks	any hydraulic jacks	any hydraulic jacks

ORDER NO.

■ 03 200 200-EU

■ 03 300 202-EU

■ 03 300 402-EU

*Without push handle **With push handle

You can find more information about suitable jacks on our website

HYDRAULIC JACK SETS

SERIES JHS

For loads up to 20 metric tons



i DESCRIPTION

■ 180° revolving housing, this allows the jack to be placed with long or with short feet to the load, if there is no space available under it.

■ **More safety** distance to the load because of the use of a separate pump and hoses.

■ **Extra-large lift height:**
JHS 5 with lift toe 240 mm, with top plate maximum 580 mm.
JHS 10 with lift toe 260 mm, with top plate maximum 610 mm.

■ Can also be used horizontally for pressing.

■ Large load capacity – up to 20 metric tons in set - with low net weight, therefore perfect for use on site or on the way due to easy change of location.

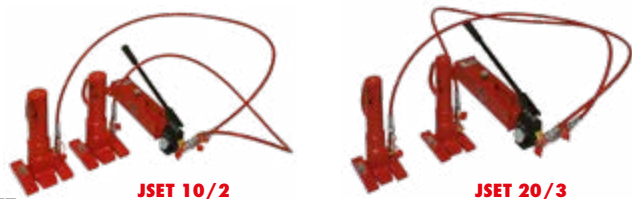

HYDRAULIC JACKS WITH PUMP AND HOSES IN ONE SET

TYPE	JSET 5/2	JSET 10/2	JSET 10/3	JSET 20/3
Jack	1 x JHS 5	2 x JHS 5	1 x JHS 10	2 x JHS 10
Hose	1 x JS 2	2 x JS 2	1 x JS 3	2 x JS 3
Pump	JP 26	JP 26	JP 26	JP 26
ORDER NO.	■ 20 405 200-S	■ 20 410 200-S	■ 20 410 301-S	■ 20 420 301-S

SINGLE HYDRAULIC JACKS JHS WITHOUT PUMP AND HOSE

TYPE	JHS 5	JHS 10	
Load capacity on top plate	kg	5000	10000
Minimum lift toe height	h 1 mm	15	20
Maximum lift toe height	h 2 mm	240	260
Top plate height	H 1 mm	350	370
Maximum top plate height	H 2 mm	580	610
Toe width front	L b mm	45	60
Usable toe depth	n L mm	40	55
Diameter top plate	d mm	60	80
Length toe supported	L 2 mm	170	205
Length toe exposed	L 1 mm	220	260
Width	B mm	145	200
Cylinder volume	L	0,3	0,47
Weight	kg	11	20
ORDER NO.	■ 01 020 050-0	■ 01 020 101-0	

i DESCRIPTION

■ JHS 10 ku as set (JSET 20/3 ku) suits perfectly to the container transport trolleys (see page 40-41).

■ High capacity at low weight.

■ Swiveling elbowed nipple allows hose connection from various directions.

■ Continuous adjustment to the load due to swiveling safety toe. Secure and stable in every situation, even in lifted position (see picture 1 page 14).

■ Pump unit separated from jack, flexible use, ideal also for confined spaces, also operates in horizontal position.

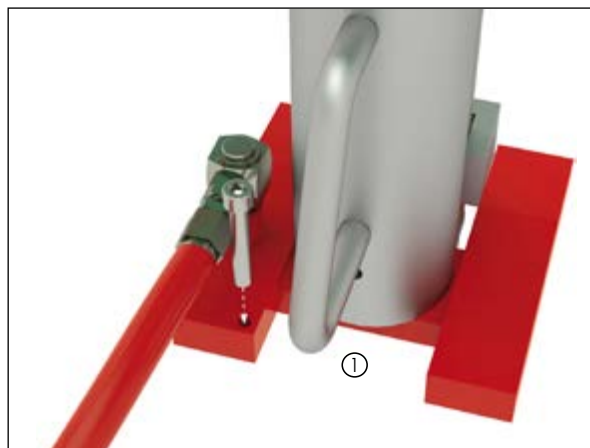

JHS 10 ku with practical swivel protection.

■ JHS 10 ku with practical swivel protection. This avoids damage to the hose (see picture 1).

External pump necessary. Please refer to page 17 for electrical pumps, page 20 for hand pumps, for hydraulic hoses to page 21.



JSET 20/3 KU

HYDRAULIC JACKS WITH PUMP AND HOSES IN ONE SET

TYPE	JSET 10/3 KU	JSET 20/3 KU
Jack	1 x JHS 10 ku	2 x JHS 10 ku
Hose	1 x JS 3	2 x JS 3
Pump	JP 26	JP 26
ORDER NO.	20 410 305-S	20 420 305-S

SINGLE HYDRAULIC JACK JHS 10 KU WITHOUT PUMP AND HOSE

TYPE	JHS 10 KU		
Load capacity on top plate		kg	10 000
Minimum lift toe height	h 1	mm	20
Maximum lift toe height	h 2	mm	288
Lift toe adjustment	V	mm	5 x 41
Top plate height	H 1	mm	265
Maximum top plate height	H 2	mm	373
Toe width front	L b	mm	60
Usable toe depth	n L	mm	55
Diameter top plate	d	mm	95
Length toe supported	L 2	mm	205
Length toe exposed	L 1	mm	260
Width	B	mm	200
Cylinder volume		Liter	0,21
Weight		kg	20
ORDER NO.	01 020 105-0		

HAND PUMP JP AND AIR HYDRAULIC PUMP JPL

Light and sturdy

i DESCRIPTION

- Sturdy construction, yet light-weight and easy to handle.
- Pressure limiting valve provides safety against overloading.
- Optimally compatible with our hydraulic jacks.
- JPL 15 with adjustable working pressure.
- Pumps are equipped with integrated quick-lift for faster working.



Handpump JP 26 with JHS 10 ku.

SUITABLE JACKS TO USE WITH A HAND PUMP/AIR HYDRAULIC PUMP

JACKS	JP 26	JPL 15
JH 6 G plus	1 to 2	1 to 2
JH 10 G plus / G plus ku / G plus EX	1 to 2	1 to 2
JH 15 G plus / G plus EX	1 to 2	1 to 2
JH 20 G plus / G plus EX	1	1 to 2
JH 30 G plus EX	-	1
JHS 5	1 to 2	1 to 2
JHS 10	1 to 2	1 to 2
JHS 10 ku	1 to 2	1 to 2

*You can find more information on our website.



HYDRAULIC HAND PUMPS

AIR HYDRAULIC PUMPS

TYPE		■ JP 26	■ JPL 15
Oil volume complete/usable	L	2,3/2,2	1,5/1,5
Working pressure	bar	520	0-700**
Flow rate without load	L/ min	-	1,07
Flow rate with load	L/ min	-	0,18
Air connection	bar	-	7-14
Flow rate per stroke	L	0,0132 (0-14 bar)/0,0023 (14-520 bar)	
Connections	pcs.	2	2
Dimensions L x W x H	mm	770 x 169* x 175	380 x 136 x 185
Weight	kg	14	9

ORDER NO.

■ 02 260 000-P

■ 02 150 000-PL

*Width foot plate **adjustable

USEFUL ACCESSORIES

For hydraulic jacks and pumps



	DIMENSIONS	CATALOGUE PAGE	ORDER NO.
01 Manometer for pumps	Ø 63 mm	17+20	94 040 024-E
02 Handle for JH 10 G plus ku and 6/10 G plus To screw on attachment – for jacks	H x W x L mm 110 x 125 x 55	14	91 106 260-B
03 Plug-on manometer For pressure testing or pressure monitoring jacks	Ø 63 mm	14-16	94 001 024-B
04 Assembly of hollow piston with spring return Re-fitting of hydraulic jacks type JH 15 G Plus Re-fitting of hydraulic jacks type JH 20 G Plus	Ø 60 mm Ø 70 mm	15 15	91 156 457-B 91 206 457-B
05 Special toe for ISO-containers For JH 6 G plus For JH 10 G plus For JH 15 G plus For JH 20 G plus	87 x 80 x 90 mm 90 x 85 x 100 mm 98 x 110 x 110 mm 98 x 110 x 110 mm	14 14 15 15	91 999 060-B 91 999 100-B 91 999 150-B 91 999 200-B
06 Adapter for hose extension JS All hoses	120 mm	21	15 999 001-NN

HYDRAULIC HOSES FOR OUR HAND PUMP, AIR HYDRAULIC PUMP, AND ELECTRICAL PUMPS:



Hydraulic hose (safety factor 4:1), max. working pressure 700 bar, oil-filled, ready for use

TYPE		■ JS 2	■ JS 3	■ JS 4	■ JS 6	■ JS ...
Drip free couplings	no.	2	2	2	2	2
Length	L = mm	2 000	3 000	4 000	6 000	variable*
ORDER NO.		■ 15 200 002-0	■ 15 300 002-0	■ 15 400 002-0	■ 15 600 002-0	■ 15 ...-002**

*available up to 15000 mm **... = ...enter L in cm

HYDRAULIC PRESSURE BLOCKS JD

Safe and powerful

WARNING! DANGER OF TILTING WITHOUT HYDRAULIC PRESSURE BLOCK

When lifting manually with four independent jacks, the load can tip over. The danger is even greater when lowering the load as this happens faster than lifting. Tipping the cargo can be the consequence.

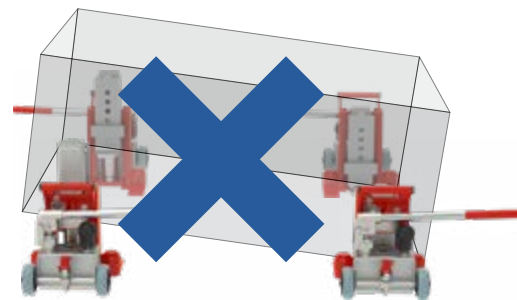

Safety with hydraulic pressure block

Advantages of working with hydraulic pressure block:

- Safer working without danger of tilting
- Time-saving
- One-person-operation

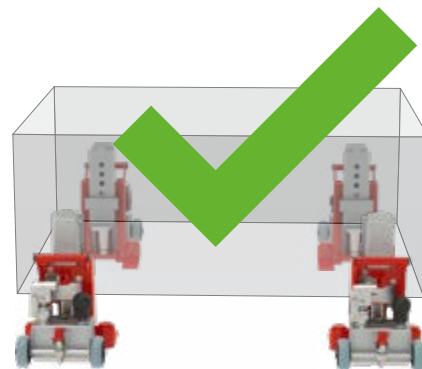

THE FOLLOWING TYPES OF PRESSURE BLOCKS ARE AVAILABLE:

TYPE			JD 40 E+ VS	JD 80 E+ VS
With electrical pump on a cart			yes	yes
Spring return			yes	yes
Dimensions length	l	mm	1 400	1 800
Dimensions width	b	mm	660	800
Dimensions height	h	mm	1 350	1 600
Working pressure		bar	520	520

ORDER NO.

04 400 403-D

04 800 405-D

Customised solutions available on request

i DESCRIPTION

■ Synchronized lifting and lowering of multiple jacks. For loads with decentralized center of gravity. Simple and safe.

■ Easy operation via push button (remote control).

■ All slave-cylinders equipped with 520 bar safety pressure valves. Controls monitor pressure switches with LED indicator preventing any possible overloading.

■ Clear and simple control unit, adjustable to control all or individual jacks. Also configurable for using three-point lifting system.

■ The complete system is mobile and conveniently mounted on a cart.

■ Retracting of the hydraulic jacks also without load (JH 15 EX - 20 Gplus EX).

■ Load independent, maintains constant lifting speed.



Hydraulic Pressure blocks JD 40 E+ VS in action

■ Controllable lowering speed.

■ Electrical pump JPE 30 and Valve control unit for driving individual lifting devices.

■ Oil volume in the system JD 40 E+ VS is sufficient for up to 4 pcs. JH 10 G plus / JH 10 G plus EX / JHS 10. Larger jacks can be operated, but you need to lift twice to reach the full stroke.

■ The cylinders in the pressure block are outfitted with spring returns to retract the pistons automatically.

JACKS TO USE WITH PRESSURE BLOCK JD 40 E+ VS	LOAD CAPACITY IN KG
4x JH 6 G plus (full stroke, without spring return)	24 000
4x JHS 5 (full stroke, without spring return)	20 000
4x JH 10 G plus (full stroke, without spring return)	40 000
4x JHS 10/JH 10 G plus ku (full stroke, without spring return)	40 000
4x JH 15 G plus (lift twice to reach full stroke, without spring return)	60 000
4x JH 15 G plus EX (lift twice to reach full stroke, with spring return)	60 000
4x JH 20 G plus (lift twice to reach full stroke, without spring return)	80 000
4x JH 20 G plus EX (lift twice to reach full stroke, with spring return)	80 000



JUNG
L O O L

JUST MOVE.

Ergonomic. Effort-saving. Efficient.



TRANSPORT TROLLEYS

SERIES K

For loads up to 24 metric tons, height: 110 mm

i DESCRIPTION

■ Equipped with premium castors as standard for smooth and reliable movement.

■ Reduced weight due to advanced construction of load cassettes.

■ Non-marking support wheels.

■ The K-series towing bars are also available with a removable handle. The removable handle is also available as a re-fitting set.

■ All transport trolleys are ready for use: The steerable transport trolley is fitted with a ball bearing supported turntable and a handlebar. The adjustable-width transport trolley consists of two transport units and connecting bar.

■ The load capacity specifications refer to a maximum speed of 2 km/h.

ACCESSORIES
Page 54-55



Loads up to		6 t		12 t	
TYPE		JLB 3 K	JFB 3 K	JLB 6 K	JFB 6 K
Load capacity	kg	3 000	2 x 1 500	6 000	2 x 3 000
Number of castors	Pieces	4	2 x 2	8	2 x 4
Castor dimensions	Ø x l mm	85 x 85	85 x 85	85 x 85	85 x 85
Height	mm	110	110	110	110
Supporting surface per cassette	E x F mm		120 x 80		170 x 170
Cassette dimensions	L2 x B2 mm		190 x 115		325 x 200
Connecting bar with joint	Length mm		1 000**		1 230
Cassettes adjustable from - to	G - H mm		125-880		400-1 030
Supporting surface of turntable	Ø C mm	150		150	
Dimensions	L1 x B1 mm	225 x 280		445 x 590	
Handlebar with pulling eye	Length mm	990*		1 210	
Weight JUWATHAN®plus	kg	12	11	34	25

ORDER NO. ■ 07 031 085-V ■ 08 031 085-V ■ 07 061 085-V ■ 08 061 085-V

*JLB 3 K steering bar without pulling eye **JFB 3 K connecting bar without joint



Castors with ball bearings guarantee easy movement.

**EXAMPLE FOR LOAD DISTRIBUTION
trolley combination:**

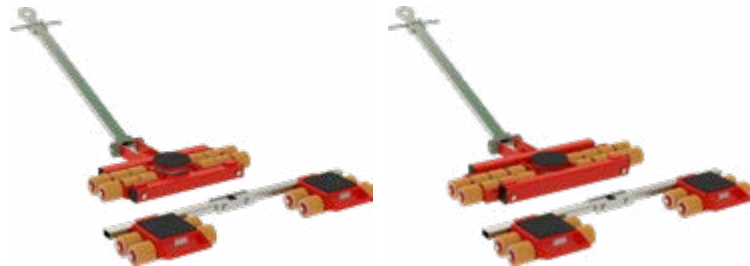
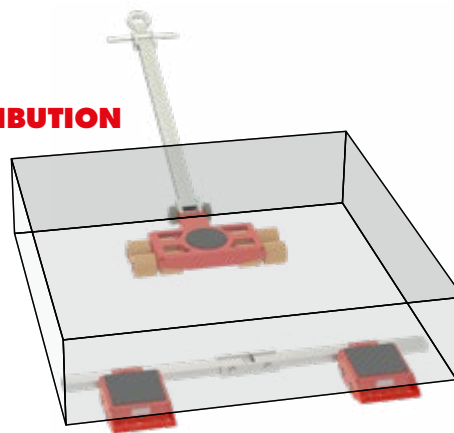

Loads up to			18 t		24 t	
TYPE			JL 9 K	JFB 9 K	JL 12 K	JFB 12 K
Load capacity	kg		9 000	2 x 4 500	12 000	2 x 6 000
Number of castors	Pieces		12	2 x 6	16	2 x 8
Castor dimensions	Ø x l	mm	85 x 85	85 x 85	85 x 85	85 x 85
Height		mm	110	110	110	110
Supporting surface per cassette	E x F	mm		170 x 170		170 x 170
Cassette dimensions	L2 x B2	mm		325 x 390		325 x 390
Connecting bar with joint	Length	mm		1 230		1 230
Cassettes adjustable from - to	G - H	mm		400-1 030		400-1 030
Supporting surface of turnable	Ø C	mm	170		170	
Dimensions	L1 x B1	mm	580 x 820		580 x 1 000	
Handlebar with pulling eye	Length	mm	1 210		1 210	
Weight JUWathan®plus	kg		49	31	62	34
ORDER NO.			07 090 085-V	08 091 085-V	07 120 085-V	08 121 085-V

TRANSPORT TROLLEYS

SERIES K PROFESSIONAL

For loads up to 28 metric tons, Height: 110 mm

i DESCRIPTION

■ The double castor design results in dramatically easier steering due to reduced friction forces in curves. The much lower friction resistance also causes the trolleys on the rear axis to follow in a true to track course.

■ Non-marking support wheels.

■ Higher capacity with professional castors, at same dimension as series K trolleys.

■ The series K handle bars are now also available with a removable handle, which is also available as a re-fitting set.

■ Because of the professional castors you need 30% less power for steering.

■ All transport trolleys are ready for use: the steerable transport trolley is fitted with a ball bearing supported turntable and a handlebar. The adjustable-width transport trolley consists of two transport units and connecting bar.

■ The load capacity specifications refer to a maximum speed of 2 km/h.

ACCESSORIES
Page 54-55



Loads up to			14 t		20 t	
TYPE			JLB 7 K	JFB 7 K	JL 10 K	JFB 10 K
Load capacity	kg		7 000	2 x 3 500	10 000	2 x 5 000
Number of twin castors	Pieces		8	2 x 4	12	2 x 6
Castor dimensions	Ø x l	mm	85 x 85	85 x 85	85 x 85	85 x 85
Height	mm		110	110	110	110
Supporting surface per cassette	E x F	mm		170 x 170		170 x 170
Cassette dimensions	L2 x B2	mm		325 x 200		325 x 390
Connecting bar with joint	Length	mm		1 230		1 230
Cassettes adjustable from - to	G - H	mm		400-1 030		400-1 030
Supporting surface of turntable	Ø C	mm	150		170	
Dimensions	L1 x B1	mm	445 x 590		580 x 820	
Handlebar with pulling eye	Length	mm	1 210		1 210	
Weight Professional	kg		35	27	56	35

ORDER NO.

■ 07 071 085-D

■ 08 071 085-D

■ 07 100 085-D

■ 08 101 085-D



Castors with ball bearings guarantee easy movement.

**▶ EXAMPLE FOR LOAD DISTRIBUTION
trolley combination:**

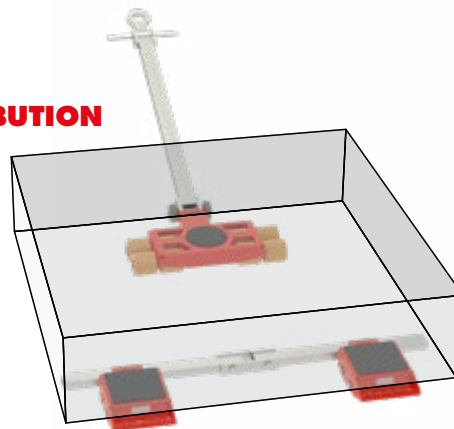

Loads up to

28 t

TYPE			JL 14 K	JFB 14 K
Load capacity	kg		14 000	2 x 7 000
Number of twin castors	Pieces		16	2 x 8
Castor dimensions	Ø x l	mm	85 x 85	85 x 85
Height	mm		110	110
Supporting surface per cassette	E x F	mm		170 x 170
Cassette dimensions	L2 x B2	mm		325 x 390
Connecting bar with joint	Length	mm		1 230
Cassettes adjustable from - to	G - H	mm		400-1 030
Supporting surface of turnable	Ø C	mm	170	
Dimensions	L1 x B1	mm	580 x 1 000	
Handlebar with pulling eye	Length	mm	1 210	
Weight Professional	kg		65	38

ORDER NO. ■ 07 140 085-D ■ 08 141 085-D

TRANSPORT TROLLEYS

SERIES S

For loads up to 48 metric tons, height 125 mm



i DESCRIPTION

■ Pivoting roller cassettes within the frame (except for JLB 16 S) assure even pressure distribution across all castors and across the floor.

■ Very low height at only 125 mm, with high capacity and low own weight.

■ All transport trolleys are ready for use: the steerable transport trolley is fitted with a ball bearing supported turntable and a handlebar (as shown in picture). The adjustable-width transport trolley consists of two transport units and connecting bars.

■ Slim castor design (60 mm fitting length) results in easier steering due to reduced friction forces also in curves.

■ The load capacity specifications refer to a maximum speed of 2 km/h.

matching
CASTORS
Page 56-57

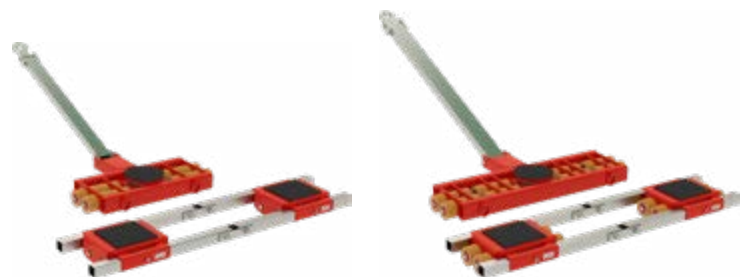

Loads up to		32 t		48 t	
TYPE		JLB 16 S	JFB 16 S	JLB 24 S	JFB 24 S
Load capacity	kg	16 000	2 x 8 000	24 000	2 x 12 000
Number of castors	Stück	16	2 x 8	24	2 x 12
Castor dimensions	Ø x l mm	90 x 60	90 x 60	90 x 60	90 x 60
Height	mm	125	125	125	125
Supporting surface per cassette	E x F mm		200 x 220		200 x 220
Cassette dimensions	L2 x B2 mm		370 x 330		370 x 465
Connecting bar with joint	Length mm		2 x 1 540		2 x 1 540
Cassettes adjustable from - to	G - H mm		540-1 300		660-1 300
Supporting surface of turntable	Ø C mm	215		215	
Dimensions	L1 x B1 mm	580 x 815		580 x 1 165	
Handlebar with pulling eye	mm	1 230		1 480	
Weight JUWAtan®	kg	82	74	124	78
ORDER NO. with JUWAtan®		■ 05 161 090-V	■ 06 161 090-V	■ 05 242 090-V	■ 06 242 090-V
ORDER NO. with steel castors		■ 05 161 090-S	■ 06 161 090-S	■ 05 242 090-S	■ 06 242 090-S



NOTIZEN / NOTES

TRANSPORT TROLLEYS

SERIES G PROFESSIONAL

For loads up to 60 metric tons, height 180 mm

i DESCRIPTION

■ From JLB 20 up, pivoting cassettes and axles within the frame assure even pressure distribution across all castors and across the floor. No need for complex and expensive hydraulic compensation system.

■ The double castor design results in dramatically easier steering due to reduced friction forces in curves. The much lower friction resistance also causes the trolleys on the rear axis to follow in a true to track course.

■ All transport trolleys are ready for use: The steerable transport trolley is fitted with a ball bearing supported turntable and a handlebar (as shown in picture). The adjustable-width transport trolley consists of two transport units and connecting bar.

■ The load capacity specifications refer to a maximum speed of 2 km/h.

TESTED

according to technical regulation ANSI/ASME (USA)

ACCESSORIES

Page 54-55



Loads up to		30 t		40 t	
TYPE		JLB 15 G	JFB 15 G	JLB 20 G	JFB 20 G
Load capacity	kg	15 000	2 x 7 500	20 000	2 x 10 000
Number of castors	Pieces	12	2 x 6	16	2 x 8
Castor dimensions	Ø x l mm	140 x 59	140 x 59	140 x 59	140 x 59
Height	mm	180	180	180	180
Supporting surface per cassette	E x F mm		220 x 120		220 x 200
Cassette dimensions	L x B x H mm		460 x 205		460 x 285
Connecting bar with joint	Length mm		2 x 1 540		2 x 1 540
Cassettes adjustable from - to	G - H mm		415 - 1 300		475 - 1 300
Supporting surface of turntable	Ø C mm	215		215	
Dimensions	L1 x B1 mm	565 x 610		565 x 741	
Handlebar with pulling eye	Length mm	1 230		1 230	
Weight JUWathan®plus	kg	92	63	96	80

ORDER NO. with JUWathan®plus

■ 09 153 140-V

■ 10 153 140-V

■ 09 203 140-V

■ 10 203 140-V



JLB 30 G and JFB 30 G

MATCHING COMBINATION TO SERIES G



JKB 10 G (p. 53)



JKB 14 G (p. 53)



JFB 30 G with Traverse (p. 42)



Loads up to

60 t

TYPE			JLB 30 G	JFB 30 G
Load capacity	kg		30 000	2 x 15 000
Number of castors	Pieces		24	2 x 12
Castor dimensions	Ø x l	mm	140 x 59	140 x 59
Height	mm		180	180
Supporting surface per cassette	E x F	mm		220 x 200
Cassette dimensions	L2 x B2	mm		460 x 400
Connecting bar with joint	Length	mm		2 x 1 540
Cassettes adjustable from - to	G - H	mm		530 - 1 300
Supporting surface of turnable	Ø C	mm	215	
Dimensions	L1 x B1	mm	565 x 995	
Handlebar with pulling eye	Length	mm	1 480	
Weight JUWATHAN®plus	kg		140	98

ORDER NO. with JUWATHAN®plus

■ 09 303 140-V

■ 10 303 140-V

TRANSPORT TROLLEYS

SERIES H PROFESSIONAL

For loads up to 200 metric tons, height 230 mm/240 mm

i DESCRIPTION

- Unrivalled: Small and light-weight trolleys at super high capacity.
- Steerable transport trolleys with pivoting cassettes for a better load distribution on all castors and the floor.
- All transport trolleys are ready for use: the steerable transport trolley is fitted with a ball bearing supported turntable and a handlebar. The adjustable-width transport trolley consists of two transport units and connecting bars.
- The double castor design results in dramatically easier steering due to reduced friction forces in curves. The much lower friction resistance also causes the castors on the rear axis to follow in a true to track course.
- The load capacity specifications refer to a maximum speed of 2 km/h.

**matching
CASTORS**
Page 56



Loads up to		80 t		120 t	
TYPE		JLB 40 H	JFB 40 H	JLB 60 H	JFB 60 H
Load capacity	kg	40 000	2 x 20 000	60 000	2 x 30 000
Number of castors	Pieces	12	2 x 6	20	2 x 10
Castors dimensions	Ø x l mm	200 x 85	200 x 85	200 x 85	200 x 85
Height	mm	230	230	230	230
Supporting surface per cassette	E x F mm		400 x 230		400 x 230
Cassette dimensions	L2 x B2 mm		740 x 300		740 x 475
Connecting bar with joint	Length mm		2 x 1 540		2 x 1 540
Cassettes adjustable from - to	G - H mm		585-1 500		700-1 500
Supporting surface of turntable	Ø C mm	250		250	
Cassette dimensions	L1 x B1 mm	670 x 920		670 x 1 275	
Handlebar with pulling eye	Length mm	1 600		1 600	
Weight JUWathan®	kg	294	222	390	322

ORDER NO. with JUWathan® ■ 09 401 206-H ■ 10 401 206-H ■ 09 601 206-H ■ 10 601 206-H

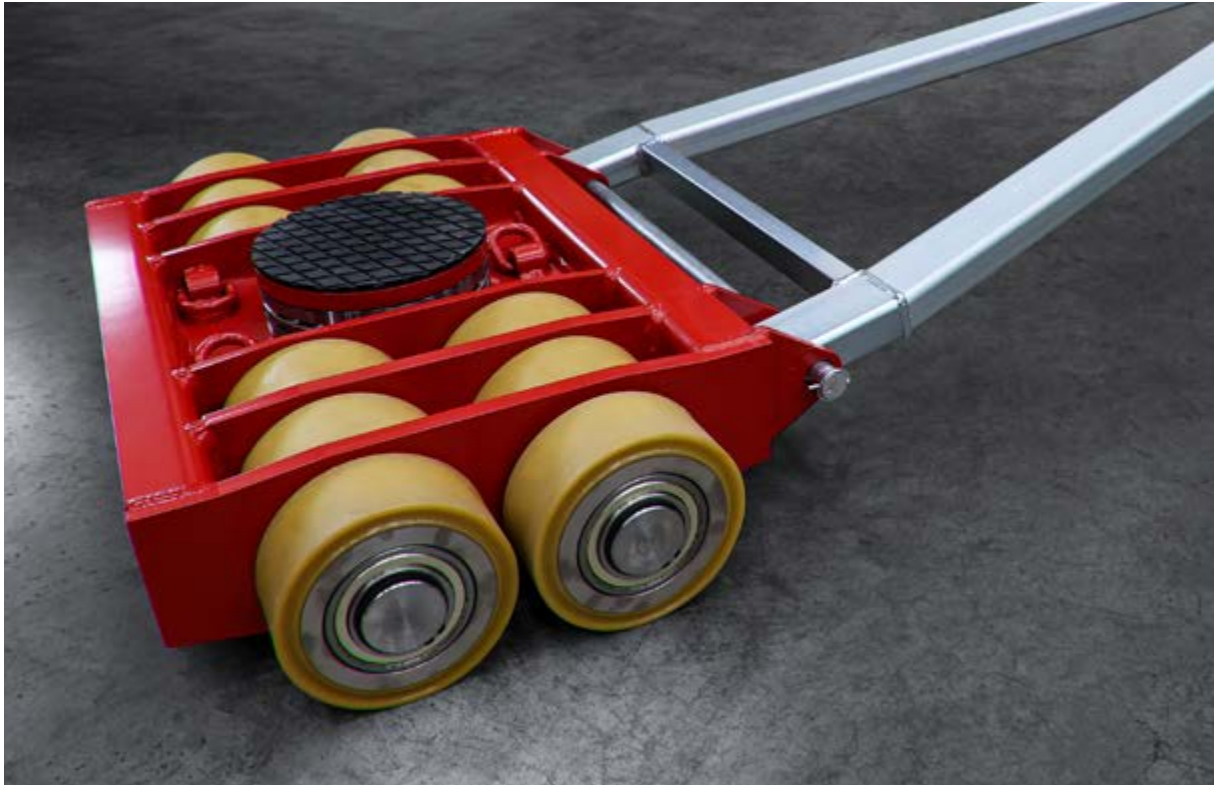

High load capacity: JLB 40 H steering system, from the H-series

**matching
CASTORS**
Page 56

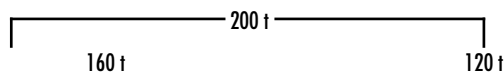
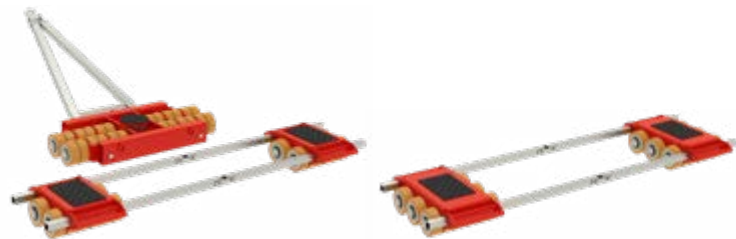

Loads up to

TYPE		JL 80 H	JFB 80 H	JFB 120 H
Load capacity	kg	80 000	2 x 40 000	2 x 60 000
Number of castors	Pieces	24	2 x 12	2 x 18
Castors dimensions	Ø x l mm	200 x 85	200 x 85	200 x 85
Height	mm	240	240	240
Supporting surface per cassette	E x F mm		400 x 230	400 x 230
Cassette dimensions	L2 x B2 mm		740 x 580	960 x 590
Connecting bar with joint	Length mm		2 x 3 000	2 x 3 000
Cassettes adjustable from - to	G - H mm		580 - 2 800	580 - 2 800
Supporting surface of turnable	Ø C mm	250		
Cassette dimensions	L1 x B1 mm	820 x 1 480		
Handlebar with pulling eye	Length mm	1 600		
Weight JUWathan®	kg	617	458	604

ORDER NO. with JUWathan®

■ 09 801 206-H

■ 10 801 206-H

■ 10 913 206-H



JUNG
L O O L

PROFESSIONALLY MOVED.

Safe. Simple. Flexible.



TANDEM TROLLEYS

SERIES K

For loads up to 14 metric tons, height 110 mm

i DESCRIPTION

■ Tandem transport trolley for loads with no leading or trailing edge center support.

■ The double castors design results in dramatically easier steering due to reduced friction forces in curves. The much lower friction resistance also causes the castors on the rear axis follow in a true to track course.

■ Non-marking support wheels.

■ Ready for use. Delivery includes two steering units, one towing bar, and 1 set of connecting rods.

An additional handlebar can be ordered as an option.

■ **Multi-purpose use:** Can also be used individually. If an additional towing bar is ordered as an accessory, steering mechanisms can be used individually at the same time, each with half the payload capacity.

■ The load capacity specifications refer to a maximum speed of 2 km/h.

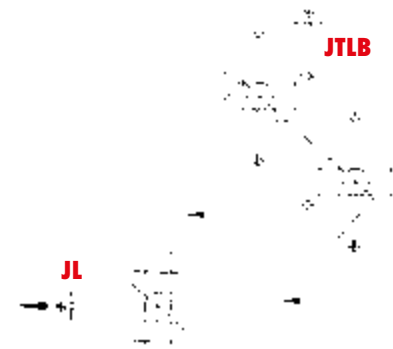

Example: For short radius curves steering possible up to 45°.



ACCESSORIES
Page 54-55

Loads up to		6 t		14 t	
TYPE		■ JTLB 6 K		■ JTLB 14 K	
Load capacity	kg	6 000		14 000	
Number of twin castors	Pieces	8		16	
Castor dimensions	Ø x l mm	85 x 85		85 x 85	
Height	mm	110		110	
Cassette dimensions	L2 x B2 mm	600 x 280		1 000 x 590	
Supporting surface per cassette	Ø C mm	150		150	
Connecting bar*	E mm	1 000		1 400	
Adjustable from - to Vmin. - Vmax.	mm	560-960		660-1 340	
Adjustable		5 x		5 x	
Total length/width	L1 x B1 mm	770 x 1 240		1 105 x 1 924	
Handlebar with pulling eye	Length mm	990		1 210	
Weight Professional	kg	47		102	

ORDER NO. Professional

■ 12 061 085-D

■ 12 121 085-D

*other lengths available on request

TANDEM TROLLEYS

SERIES G PROFESSIONAL

For loads up to 30 metric tons, height 180 mm

i DESCRIPTION

■ Big castors Ø 140 mm x width 59 mm provide optimal rolling characteristics on uneven surfaces and rough pavements.

■ Safely overcomes small ledges, cracks in the concrete and countersunk rail tracks.

■ Custom solutions available.

■ Ready for use: delivery includes 2 steering units, 1 towing bar and 1 set of connecting rods per tandem. An additional handlebar can be ordered as an option.

■ **Multi-purpose use:** Can also be used individually. If an additional towing bar is ordered as an accessory, steering mechanisms can be used individually at the same time, each with half the payload capacity.

■ The load capacity specifications refer to a maximum speed of 2 km/h.



Example: For short radius curves steering possible up to 45°.



Loads up to			20 t	30 t
TYPE			JTL 20 G	JTLB 30 G
Load capacity		kg	20 000	30 000
Number of castors		Pieces	16	24
Castor dimensions	Ø x l	mm	140 x 59	140 x 59
Height		mm	180	180
Supporting surface of turntable	Ø C	mm	170	215
Cassette dimensions	L2 x B2	mm	1 020 x 440	1 380 x 610
Width of track and connection rod*	E	mm	1 330	1 700
Adjustable from - to Vmin. - Vmax.		mm	900-1 230	1 270-1 600
Adjustable			3 x	3 x
Dimensions	L1 x B1	mm	1 260 x 1 670	1 620 x 2 200
Handlebar with pulling eye	Length	mm	1 230	1 230
Weight JUWATHan®plus		kg	168	283

ORDER NO. with JUWATHan®plus

■ 12 202 140-V

■ 12 302 140-V2

*other lengths available on request

TANDEM TROLLEYS "WELD-ON CONE"

For transporting containers up to 28 metric tons, height 170 mm

i DESCRIPTION

- „Weld-on Cone“ version for indoor container transport on smooth floors includes turntables fitted with cones and 2-parts container-wide connecting bars fixed length 2.26 m; also including a handlebar with towing eye.
- Containers can be moved with extremely low installation height.
- Form-fitting-hold between the trolley and the containers (Weld-on Cone System).
- Safe transport of containers.
- Compatible with all ISO-containers.
- Upgrade to Twistlock system possible.
- The load capacity specifications refer to a maximum speed of 2 km/h.



Weld-on Cone



Twistlock

**ACCES-
SORIES**

Page 55

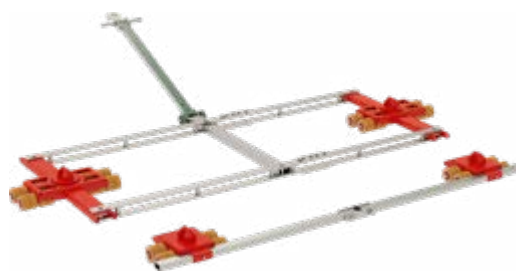

„Weld-on Cone“ system for Series K

TYPE			■ JTLB 14 K WOC	■ JFB 14 K WOC
Height	h1	mm	110	110
Total height	h2	mm	170	170
ISO-length	V	mm	2260	2260
Dimensions steerable	L1 x B1	mm	1120 x 2850	-
Dimensions straight-line	L2 x B2	mm	-	325 x 2650
Weight		kg	120	45

ORDER NO.

■ 12 121 085-WZ

■ 08 141 085-WOC

TANDEM TROLLEYS TWISTLOCK

For transporting containers up to 60 metric tons, height 300 mm

i DESCRIPTION

■ "Twistlock" version for outdoor transport on paved surfaces. Includes turntables fitted with "Twistlock" to secure containers to transport trolleys. Including 2-parts connecting bars fixed length 2.26 m and handlebar with towing eye.



■ Safe transport of containers.

■ Containers can be moved with extremely low installation height.

■ Lock-to-hold mechanism between the trolley and the containers (Twistlock).

■ Compatible with all ISO-containers.

■ The load capacity specifications refer to a maximum speed of 2 km/h.



Also
AVAILABLE
with extended track rods
on request.



Twistlock system for Series G
Please refer to page 32-33 for technical details

TYPE			JTL 20 G TL	JFB 20 G TL	JTLB 30 G TL	JFB 30 G TL
Height	h1	mm	215	215	215	215
Total height	h2	mm	300	300	300	300
ISO-length	V	mm	2260	2260	2260	2260
Dimensions steerable	L1 x B1	mm	1260 x 2700	-	1620 x 2870	-
Dimensions straight-line	L2 x B2	mm	-	460 x 3000	-	460 x 3000
Weight		kg	215	114	323	140

BESTELNR.	JTL 20 G TL	JFB 20 G TL	JTLB 30 G TL	JFB 30 G TL
	12 203 140-TL	10 203 140-TL	12 303 140-TL	10 303 140-TL

CONTAINER-TRAVERSE

With Twistlock-fitting up to 36 metric tons, height 260 mm

! Additional mounting hardware/drill holes for the traverse are offered to suit the specific application.

i DESCRIPTION

- Safe transport of ISO-containers and special containers up to 36 metric tons.
- Containers can be moved with extremely low installation height.
- Assembled in two parts for easy handling and storage.
- Compatible with all ISO containers.
- Lockable twistlock version to ISO dimension 2.26 m (not adjustable).
- Optionally a trapezium draw-bar can be adapted.
- The dimension of the traverse is within the container contour.
- For the T1 and T2 container traverse, the load is firmly secured. With the T3 traverse, the load rests on top of a trolley.
- Installation height of the cross-bar: 80 mm.

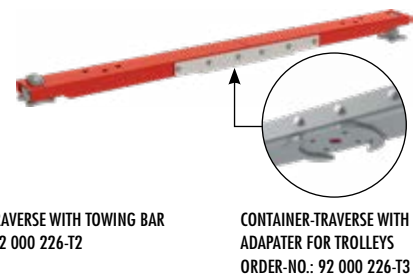

POSSIBLE COMBINATIONS:

STEERABLE TROLLEYS	ORDER NO. TROLLEY	ORDER NO. CONTAINER-TRAVERSE WITH ACCESSORIES	TRANSPORT TROLLEYS	ORDER NO. TRANSPORT TROLLEYS	ORDER NO. CONTAINER-TRAVERSE WITH ACCESSORIES	LOAD CAPACITY IN KG*
JLA-e 5/12 G	22 005 200-G	92 000 226-T3	1x JFB 7 K	08 071 085-DH	92 000 226-T1	12 000
JLA-e 5/12 G mit Hub	22 005 210-G Hub	92 000 226-T3	1x JFB 7 K	08 071 085-DH	92 000 226-T1	12 000
2 x JKB 4 K	2 x 14 041 085-VU	92 000 226-T2	1 x JFB 7 K	08 071 085-D	92 000 226-T1	15 000
1x JLF 5	16 050 085-D	92 000 226-T3	2 x JLF 5	2 x 16 050 085-D	92 000 226-T1	15 000
2 x JLF 5	2 x 16 050 085-D	92 000 226-T2	2 x JLF 5	2 x 16 050 085-D	92 000 226-T1	20 000
2 x JKB 6 K	2 x 14 061 085-VU	92 000 226-T2	1 x JFB 10 K	08 101 085-D	92 000 226-T1	22 000
2 x JKB 8 K	2 x 14 080 085-VU	92 000 226-T2	1 x JFB 14 K	08 141 085-D	92 000 226-T1	29 000
1 x JTLB 14 K	1x 12 121 085-D	92 000 226-T1	1 x JFB 14 K	08 141 085-D	92 000 226-T1	28 000
1 x JLB 15 G	09 153 140-V	92 000 226-T3	1x JFB 15 G	10 153 140-V	92 000 226-T1	30 000
JLA-e 15/30 G	22 015 200-G	92 000 226-T3	1 x JFB 15 G	10 153 140-V	92 000 226-T1	30 000
JLA-e 15/30 G mit Hub	22 015 210-G Hub	92 000 226-T3	1 x JFB 15 G	10 153 140-V	92 000 226-T1	30 000
2 x JKB 10 G	2 x 14 103 140-VU	92 000 226-T2	1 x JFB 20 G	10 203 140-V	92 000 226-T1	36 000
2 x JKB 14 G	2x 14 143 140-VU	92 000 226-T2	1 x JFB 30 G	10 303 140-V	92 000 226-T1	36 000
1x JTL 20 G	12 203 140-V	92 000 226-T1	1 x JFB 20 G	10 203 140-V	92 000 226-T1	36 000
1 x JTLB 30 G	12 303 140-V	92 000 226-T1	1 x JFB 30 G	10 303 140-V	92 000 226-T1	36 000
1x JLB 20 G	09 203 140-V	92 000 226-T3	1x JFB 20 G	10 203 140-V	92 000 226-T1	36 000
1 x JLB 30 G	09 303 140-V	92 000 226-T3	1x JFB 30 G	10 303 140-V	92 000 226-T1	36 000
1 x JLAe 25/50H	22 025 200-H	92 000 226-T3	1 x JFB 25 G	10 251 141-V	92 000 226-T1	36 000
1 x JLAe 25/50H	22 025 200-H	92 000 226-T3	1 x JFB 40 H	10 401 206-H	92 000 226-T1	36 000

*Load must rest as a surface load on Container-Traverse.

EXAMPLES OF USE CONTAINER-TRAVERSE

Example: Container traverse suitable for standard tandem steering systems. The traverse is firmly connected to the turntables by screwing and thus forms a secure transport unit.



UPON REQUEST

Special dimensions and higher load capacities available.



JACK WITH SPECIAL TOE FOR CONTAINERS

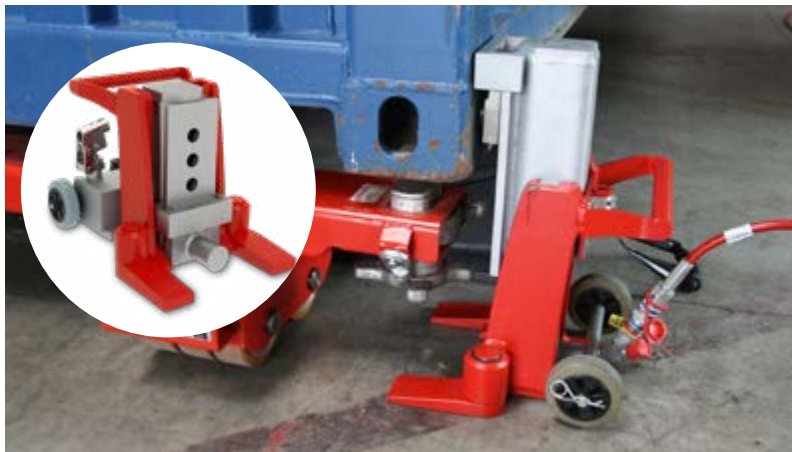

Hydraulic jack with special toe for containers:

The special toe fits in the container corners for safe lifting of ISO containers, can also be upgraded. Available for all hydraulic jacks series G-plus, G-Plus EX, and JHS 10 ku (see page 14-16, 19).

EXAMPLES OF POSSIBLE COMBINATIONS CONTAINER-TRAVERSE:



JFB 30 G with traverse T1



JLA-e 15/30 G with traverse T3



JKB 10 G with traverse T2

MOVE **FLEXIBLY.**

Agile. Easy. Efficient.



JUNG
L O O L



MULTI-PURPOSE TROLLEYS SERIES M

For loads up to 15 metric tons, height 150 mm

i DESCRIPTION

- Combines leading swiveling castors with trailing rigid castors. Swiveling lead-castors make steering easier by up to 80%.
- Ergonomic: Reduces handling effort for user.
- Better directional stability on long straight-line paths with trailing rigid castors.
- Trolleys can be used as steerable, adjustable or tandem trolley.
- Low installation height. Low weight.
- Extremely manoeuvrable thanks to ball-bearing turntable with anti-slip coating.
- Ideal for transporting loads on slalom paths including 90° true-to-course straightline, turning and sideways maneuvering.
- Floor protective, non-marking coating.
- Each trolley can be used for either steerable or straight-line movements.
- An additional towing bar for steering rear-trailing trolleys and achieving a tighter turning radius is included in the set.
- The load capacity specifications refer to a maximum speed of 2 km/h.

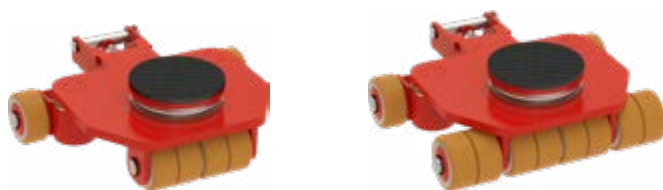

Loads up to		3,5 t	5 t
TYPE		JLF 3,5	JLF 5
Load capacity	kg	3 500	5 000
Number of castors / twin castors	Pieces	4/2	4/4
Castor dimensions	mm	85 x 43	85 x 43
Height	mm	150	150
Supporting surface per cassette	Ø C mm	150	150
Dimensions	L1 x B1 mm	410 x 420	410 x 420
Handlebar with pulling eye		-	-
Connecting bar		-	-
Weight JUWathan®plus	kg	25	28

ORDER NO. **16 035 085-D** **16 050 085-D**

Registered design EU No. 002267487 - 001 European patent No. 2 662 261 B1



Example as tandem transport trolley



Example as adjustable trolley

ALSO WITH CONTAINER TRAVERSE

(p. 42-43)

TESTED
according to technical regulation ANSI/ASME (USA)

matching CASTORS
Page 56-57



Loads up to

12 t

15 t

TYPE		JLF SET 12	JLF SET 15
Load capacity	kg	1 x 5 000 + 2 x 3 500	3 x 5 000
Number of castors/twin castors	Pieces	3 x 4/2 x 2 + 1 x 4	3 x 4/3 x 4
Castor dimensions	mm	85 x 43	85 x 43
Height	mm	150	150
Supporting surface per cassette	Ø C mm	150	150
Dimensions	L1 x B1 mm	410 x 420	410 x 420
Handlebar with pulling eye	L mm	1 210	1 210
Connecting bar	Ø x L mm	20 x 1 200	20 x 1 200
Weight JUWathan®plus	kg	89	95
ORDER NO.		16 120 085-D	16 150 085-D

360° MOVEMENT.

Precise. Efficient. Compact.





JUNG

REVOLVING TRANSPORT TROLLEYS JKB

For loads up to 12 metric tons, height 110* mm



i DESCRIPTION

- Optional connecting bars can be fixed without tools by clamping down on adapter.
- High load capacity at low weight.
- Bearing supported swiveling castors allow 360° maneuverability.
- Mix and match revolving trolleys with transport trolleys: JKB 2 to JKB 8 have the same height as transport trolleys series K.
- All products are also available in a set of two with price advantage.

- In addition, all the trolleys have a platform center hole to allow attachment to the load.
- Handle bar and connecting bars available as accessories (see page 54).
- **With locking mechanism:** for fixing the castors in place so that the track is maintained even on uneven floors or when changing direction. The directional lock can be secured or released under load. Can be used for electrically powered chassis as a trailer or steering wheel, as the castors run true to track.
- When using 2 units of JKB 2 with locking mechanism, we recommend using the connecting rod (see pages 54-55).

- **Unrivalled:** The narrow castors reduce rolling and turning resistance to a minimum.
- For choosing the adequate revolving trolley we recommend a load of two-third of the maximum capacity. This will be the most advantageous compromise between payload, ergonomics and handling of the devices.
- The load capacity specifications refer to a maximum speed of 2 km/h.



From June 2026
All revolving transport
WITH LOCKING MECHANISM



Loads up to		2 t		4 t	
TYPE		■ JKB 2 K		■ JKB 4 K	
Load capacity	kg	2000		4000	
Number of castors	Pieces	6		12	
Castor dimensions	Ø x l mm	85 x 43		85 x 43	
Height	mm	110*		110*	
Supporting surface per cassette	Ø C mm	150		250	
Cassette dimensions	L1 x B1 mm	528 x 495		690 x 475	
Weight JUWAmid	kg	20		37	
ORDER NO. with JUWAmid		■ 14 020 085-P		■ 14 042 085-P	
ORDER NO. with JUWathan®		■ 14 020 085-VU		■ 14 042 085-VU	

*Due to technical changes, there may be tolerances of up to + 4.5 mm in the installation height since 2014.



Revolving trolley JKB with directional lock

**EXAMPLE FOR LOAD DISTRIBUTION
trolley combination:**

The K-Series revolving transport trolleys are also available
WITH WHITE
 Polyamide-Wheels
 Upgrade item number: 92 050 091-P

Locking of the rear revolving transport trolleys.

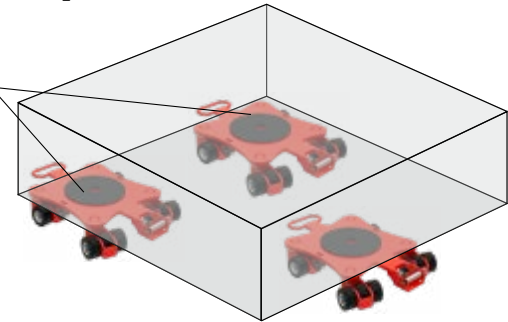

**matching
CASTORS**
Page 56-57



6 t

Loads up to

TYPE		JKB 6 K	
Consist of		1 x JKB 6 K	
Load capacity	kg	6 000	
Number of castors	Pieces	16	
Castor dimensions	Ø x l mm	85 x 43	
Height	mm	110*	
Supporting surface per cassette	Ø C mm	250	
Cassette dimensions	L1 x B1 mm	675 x 525	
Weight JUWAmid	kg	41	

ORDER NO. with JUWAmid

■ 14 061 085-P

ORDER NO. with JUWAtan®

■ 14 061 085-VU

*Due to technical changes, there may be tolerances of up to + 4.5 mm in the installation height since 2014.

REVOLVING TRANSPORT TROLLEYS JKB

For loads up to 28 t metric tons, height 110* mm/180 mm

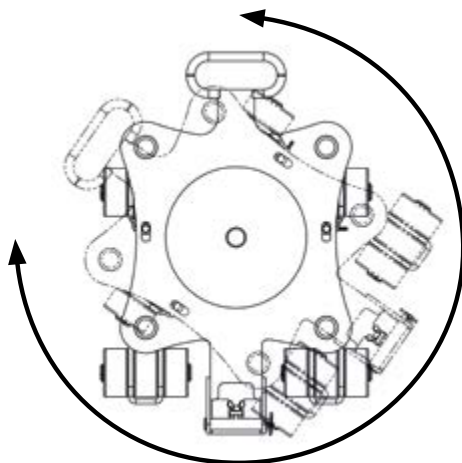

Remains on track thanks to locking



Revolving trolley JKB in action

The K-Series revolving transport trolleys are also available
WITH WHITE
 Polyamide-Wheels
 Upgrade item number: 92 050 091-P

**ACCES-
SORIES**
Page 55



Loads up to			8 t
TYPE			JKB 8 K
Load capacity	kg		8 000
Number of castors	Pieces		20
Castor dimensions	Ø x l	mm	85 x 43
Height		mm	110*
Supporting surface per cassette	Ø C	mm	250
Cassette dimensions	L1 x B1	mm	895 x 740
Weight JUWAmid	kg		65,5
ORDER NO. with JUWAmid			14 080 085-P
ORDER NO. with JUWathan®			14 080 085-VU

*Due to technical changes, there may be tolerances of up to + 4.5 mm in the installation height since 2014.



NEW: WITH LOCKING!

FROM JUNE 2026

TESTED
according to technical
regulation ANSI/ASME
(USA)

i DESCRIPTION

■ JKB 10 G/JKB 14 G have the same height as transport trolleys series G.

■ High load capacity at low weight.

■ Bearing supported swiveling castors allow 360° maneuverability.

■ All products are also available in a set of two with price advantage.

■ In addition, all the trolleys have a platform center hole to allow attachment to the load.

■ **With locking mechanism:** for fixing the castors in place so that the track is maintained even on uneven floors or when changing direction. The directional lock can be secured or released under load. Can be used for electrically powered chassis as a trailer or steering wheel, as the castors run true to track.

■ **Unrivalled:** The narrow castors reduce rolling and turning resistance to a minimum.

■ Towing bar as accessories (see pages 54).

■ For choosing the adequate revolving trolley we recommend a load of two-third of the maximum capacity. This will be the most advantageous compromise between payload, ergonomics and handling of the devices.

■ The load capacity specifications refer to a maximum speed of 2 km/h.

From June 2026
All revolving transport
WITH LOCKING MECHANISM

**matching
CASTORS
Page 56-57**



Loads up to

10 t

14 t

TYPE		JKB 10 G	JKB 14 G
Load capacity	kg	10 000	14 000
Number of castors	Pieces	8	12
Castor dimensions	Ø x l mm	140 x 59	140 x 59
Height	mm	180	180
Supporting surface per cassette	Ø C mm	250	250
Cassette dimensions	L1 x B1 mm	975 x 665	975 x 720
Weight JUWathan®	kg	127	152

ORDER NO. with JUWathan®

■ 14 103 140-VU

■ 14 143 140-VU

USEFUL ACCESSORIES

For transport trolleys



TRANSPORT TROLLEYS SERIES K		HANDLE BAR WITH TOWING EYE	TOWING BAR COMPLETE WITH REMOVABLE HANDLE	REMOVABLE HANDLE	EXTENDED CONNECTING BAR
		JLB 3 K	JLB 6 K - JL 14 K	JLB 6 K - JL 14 K	JFB 6 K - JFB 14 K
Dimensions	mm	1 120 length	1 210 length	330 x 45 x 40	2 360 length
Catalogue page		26	26-29	26-29	26-29
ORDER NO.		■ 92 010 148-B	■ 92 010 122-B	■ 92 090 300-B	■ 92 010 063-B



REVOLVING TRANSPORT TROLLEYS JKB 2 K - JKB 8 K		HANDLE BAR	CONNECTING ROD	
		JKB 2 K - JKB 8 K	JKB 2 K	JKB 4 K - JKB 8 K
Dimensions	mm	1070 length	1 200 length	2 400 length (2 x 1 200)
Catalogue page		50-52	50	50-52
ORDER NO.		■ 92 030 085-L	■ 92 030 085-V	■ 92 040 085-V



REVOLVING TRANSPORT TROLLEYS JKB 10 G - JKB 14 G		TOWING BAR
		JKB 10 G - JKB 14 G
Dimensions	mm	on request
Catalogue page		53
ORDER NO.		■ 92 226 042-B



MULTI-PURPOSE TROLLEYS SERIE M		HANDLE BAR WITH TOWING EYE	CONNECTING ROD
		JLF 3,5 - JLF 5	JLF 3,5 - JLF 5
Dimensions	mm	1 210 length	1 200 length
Catalogue page		46	46
ORDER NO.		■ 92 010 022-B	■ 92 030 085-V



TANDEM TROLLEYS		EXTENDED CONNECTING ROD		
		JTLB 6 K	JTLB 14 K	JTL 20 G & JTLB 30 G
Dimensions	mm	Length on request	Length on request	Length on request
Catalogue page		38	38	39
ORDER NO.		■ 92 010 160-B	■ 92 010 161-B	■ 92 010 163-B



TRANSPORT TROLLEYS SERIES G		EXTENDED CONNECTING ROD
		JFB 15 G - JFB 30 G
Dimensions	mm	3 000 length (two-piece)
Catalogue page		32-33
ORDER NO.		■ 92 090 060-B



Our transport boxes can be moved with pallet trucks and forklifts!



TRANSPORT BOXES		TOOL BOX
		On request
Dimensions	mm	1 200 x 800 x 500
Suitable for		2x JH 6 or 2x JH 10 G Plus, as well as one set of JLB / JFB 6 or 7 K professional
ORDER NO.		■ 92 120 800-TK

STURDY CASTORS FOR ANY APPLICATION

High quality coatings

DESCRIPTION

■ **JUWathan®** castor design: The coating is molded around a steel core. Two precision ball bearings are pressed into the steel core.

■ **JUWathan®plus** castor design: The basis of the **JUWathan®** castor is a further advanced coating (plus) based on **JUWathan®plus** castor. A coating of a special polyurethane-based compound is applied to an aluminium core. The thickness of the rubber has been optimised to such an extent that the rolling resistance is reduced by more than 30 %. A weight saving of almost 35 % per castor was also achieved by the new construction.

■ **JUWathan® Professional:** The professional series castor was developed based on the **JUWathan®plus** castor. The side-by-side double castor system provides higher load capacity (2x2 ball bearings) and offers greatly reduced rolling resistance. Turning of the steerable trolley requires less force because the castors can turn against one another resulting in extremely reduced friction between surface and castor. The much lower friction resistance also causes directional stability.

■ The load capacity specifications refer to a maximum speed of 2 km/h.



JUWathan® plus		SERIES K	SERIES K PROFESSIONAL	JKB	SERIES G
Load capacity	kg	750	875	375	1 250
Dimensions	D x l mm	85 x 85	85 x 85	85 x 43	140 x 59
Inside diameter	d mm	25	25	25	35
Weight	kg	0,8	1,05	0,5	1,85
ORDER NO.		■ 95 050 057-V	■ 95 050 089-D	■ 95 050 131-V	■ 95 050 047-V



JUWathan®		SERIES S	SERIES H
Load capacity	kg	1 000	2 500
Dimensions	D x l mm	90 x 60	200 x 83
Inside diameter	d mm	25	70
Weight	kg	1,2	9,05
ORDER NO.		■ 95 050 304-V	■ 95 050 390-D

*We grant a 5-year warranty on the operability of our JUWathan® castors, except in cases of improper use or normal wear.

DESCRIPTION

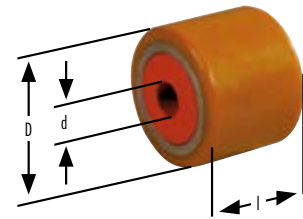

■ **JUWAmid**-castor design: Two precision ball bearings are pressed into a high quality polyamid coating.

■ **Steel** castor design: The steel body is made of a seamless steel tube. Two precision ball bearings are pressed into the steel core.

RECOMMENDED USE

Recommended use for	Castor type and coat		
	JUWAtan® JUWAtan® plus JUWAtan® Professional	JUWAmid	Steel
Plain and clean floors	✓	✓	
For any floors, swarf resistant	✓		
Bad floors with roughness			✓



JUWAmid			■ JKB	■ JKB	■ SERIES K
Load capacity		kg	375	375	750
Dimensions	D x l	mm	85 x 43	85 x 43	85 x 85
Inside diameter	d	mm	25	25	25
Weight		kg	0,35	0,35	0,85
ORDER NO.			■ 95 050 088-P	■ 95 050 091-P	■ 95 050 023-P



STEEL			■ SERIES K	■ SERIES S
Load capacity		kg	750	1 000
Dimensions	D x l	mm	85 x 85	90 x 60
Inside diameter	d	mm	25	25
Weight		kg	2,4	2,8
ORDER NO.			■ 95 050 043-S	■ 95 050 305-S

MOVE **INNOVATIVELY.**

Flexible. Driven. Efficient.



JUNG



TROLLEYS

ELECTRIC-POWERED

For loads up to 50 metric tons, height 180 mm/230 mm

i DESCRIPTION

- Practical, with battery and handy remote control! The remote control can be switched from two-handed to one-handed operation (flexible left/right). The one-handed operation allows to move the trolley exactly straight ahead.
- Spare a towing vehicle.
- Very compact dimensions.
- Low charging time of 4-5 h; Alternatively high-speed charger = 2-3 h. Available as accessory.
- Batteries are interchangeable.
- High running time (at full load under ideal conditions) by direct-driven motor.
- 360° maneuverable.
- Continuously adjustable speed.
- Compatible with series G (p. 32-33) and series H (p. 34-35). Transport trolleys are not included
- LiFePo4 battery technology.
- **Scope of delivery:** JLA-e, remote control, and charger. JLA-e cable connection for the remote control.



Loads up to		12 t		30 t	
TYPE		■ JLA-E 5/12 G		■ JLA-E 15/30 G	
Load capacity	kg	5 000		15 000	
Pulling capacity	kg	12 000		30 000	
Number of castors	Pieces	4		16	
Castor dimensions	Ø x l mm	140 x 59		140 x 59	
Height	mm	180		180	
Supporting surface of turnable	Ø C mm	150		215	
Dimensions	L1 x B1 mm	750 x 900		835 x 1215	
Weight without battery + controller	kg	146		198	
Weight battery + box	kg	45		45	
Weight charger	kg	2		2	
Speed	m/min	10		6,5	
Operational time	h	4-5		4-5	
Operating mode in acc. with VDE 0530		S1		S3 60%	
Battery and charger	Pieces	1 x		1 x	
Remote control, charger and belt with holder	Pieces	1 x		1 x	

ORDER NO. ■ 22 005 200-G ■ 22 015 200-G

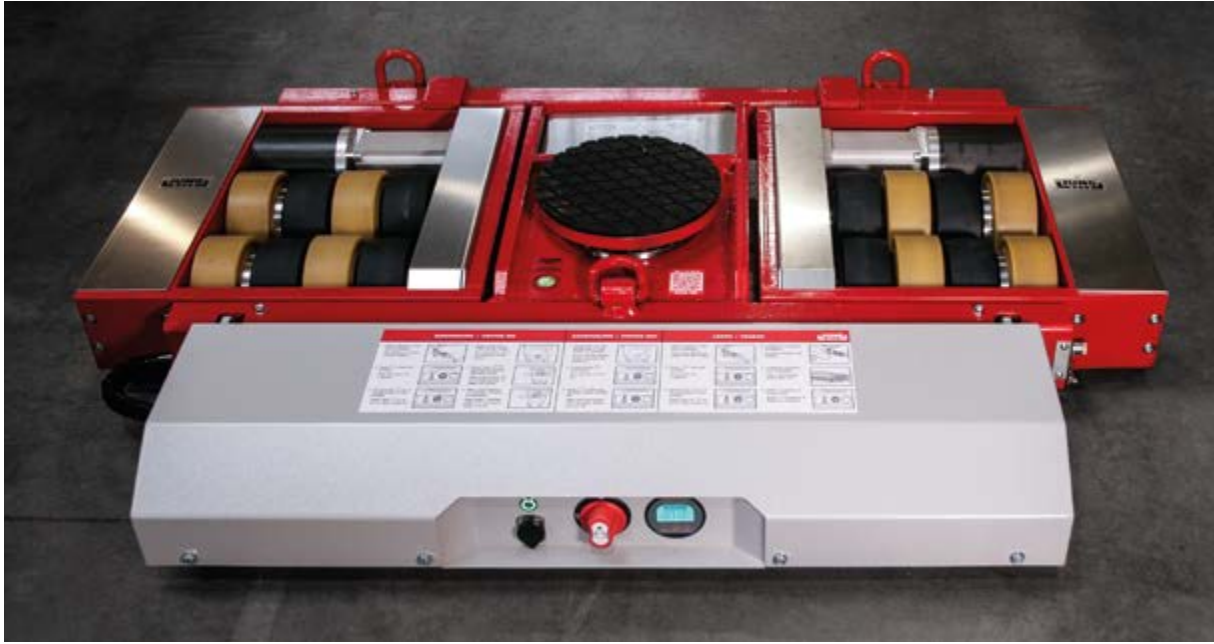

Trolley JLA-e 15/30 G facelift

JLA-e
ACCES-
SORIES
 Page 66-67



Loads up to

50 t

TYPE		■ JLA-E 25 / 50 H	
Load capacity	kg	25 000	
Pulling capacity	kg	50 000	
Number of castors	Pieces	16	
Castor dimensions	Ø x l mm	200 x 83	
Height	mm	230	
Supporting surface of turntable	Ø C mm	250	
Dimensions	L1 x B1 mm	1 140 x 1 750	
Weight without battery + controller	kg	578	
Weight battery + box	kg	45	
Weight charger	kg	2	
Speed	m/min	10	
Operational time	h	2-3	
Operating mode in acc. with VDE 0530		S3 60%	
Battery and charger	Pieces	1 x	
Remote control, charger and belt with holder	Pieces	1 x	

ORDER NO.

■ 22 025 200-H

JLA-E TROLLEY CONFIGURATIONS

i DESCRIPTION

- Practical, with battery and handy remote control! The remote control can be switched from two-handed to one-handed operation (flexible left/right). The one-handed operation allows to move the trolley exactly straight ahead.
- Spare a towing vehicle.
- Very compact dimensions.
- Low charging time of 4-5 h; Alternatively high-speed charger = 2-3 h. Available as accessory.
- Batteries are interchangeable.
- High running time (at full load under ideal conditions) by direct-driven motor.
- 360° maneuverable.
- Continuously adjustable speed.
- Compatible with series G (p. 32-33) and series H (p. 34-35). Transport trolleys are not included
- LiFePo4 battery technology.
- **Scope of delivery:** JLA-e, remote control, and charger. JLA-e cable connection for the remote control.



JLA-E CONFIGURATIONS

TYP			■ JLA-E 5/12 G	■ JFB 7 K	■ JLA-E 15/30 G	■ JFB 15 G
Load capacity	kg		5 000	2 x 3 500	15 000	2 x 7 500
Pulling capacity	kg		12 000		30 000	
Number of castors	Pieces		4	2 x 4	16	2 x 6
Castor dimensions	Ø x l	mm	140 x 59	85 x 85	140 x 59	140 x 59
Height	mm		180	180	180	180
Supporting surface of turnable	Ø C	mm	150	170 x 170	215	220 x 120
Dimensions	L1 x B1	mm	750 x 900	325 x 200	835 x 1215	460 x 205
Weight without battery + remote control	kg		146	27	198	71
Weight with battery + Box	kg		45		45	
Weight charger	kg		2		2	
Speed	m/min		10		6,5	
Operational time	h		4-5		4-5	
Operating mode in acc. with VDE 0530			S1		S3 60%	
Battery with charger	Pieces		1 x		1 x	
Remote control, charger and belt with holder	Pieces		1 x		1 x	

BESTELL-NR. ■ 22 005 200-G ■ 08 071 085-DH ■ 22 015 200-G ■ 10 153 140-V

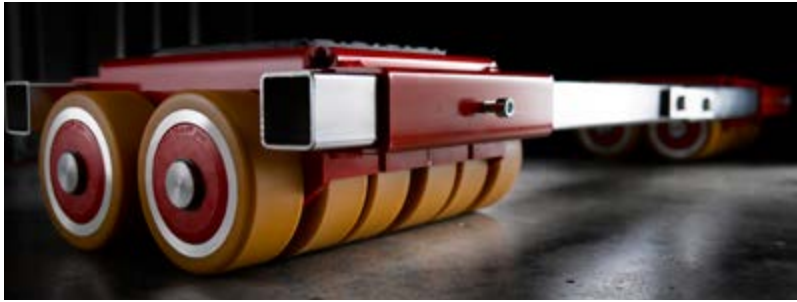

JFB 25 G

i TROLLEY CONFIGURATIONS

Includes:

- Electric-powered trolley.
- High performance accumulator with pulse charging device.
- Remote control with battery, charger and belt holder. The remote control can be switched from two-handed to one-handed operation - flexible (left/right).
- Adequate transport trolley.



Pulse charger



radio remote control



belt pouch.



JLA-E CONFIGURATIONS

TYP		■ JLA-E 25/50 H	■ JFB 25 G
Load capacity	kg	25 000	2 x 12 500
Pulling capacity	kg	50 000	
Number of castors	Pieces	16	2 x 10
Castor dimensions	Ø x l mm	200 x 83	140 x 59
Height	mm	230	230
Supporting surface of turnable	Ø C mm	250	220 x 120
Dimensions	L1 x B1 mm	1 140 x 1 750	460x330
Weight without battery + remote control	kg	578	90
Weight with battery + Box	kg	45	
Weight charger	kg	2	
Speed	m/min	10	
Operational time	h	2-3	
Operating mode in acc. with VDE 0530		S3 60%	
Battery with charger	Pieces	1 x	
Remote control, charger and belt with holder	Pieces	1 x	

BESTELL-NR.

■ 22 025 200-H

■ 10 251 141-V

TROLLEYS WITH STROKE

ELECTRIC-POWERED

For loads up to 30 metric tons, height 180 mm/200 mm

i DESCRIPTION

- Stroke max. 50 mm. The load can be moved in the extended state.
- Practical, with battery and handy remote control. The remote control can be switched from two-handed to one-handed operation (flexible left/right). The one-handed operation allows to move the trolley exactly straight ahead.
- High running time (at full load under ideal conditions) by direct-driven motor.
- Low charging time of 4-5 h; Alternatively high-speed charger = 2-3 h. Available as accessory.
- Spare a towing vehicle.
- Operating mode according to VDE0530.
- 360° maneuverable.
- Continuously adjustable speed.
- Very compact dimensions.
- Compatible with series G (p. 32-33). Transport trolleys are not included.
- LiFePo4 battery technology.

JLA-e
ACCES-
SORIES
Page 66-67



Loads up to

12 t

TYPE		■ JLA-E 5/12 G WITH STROKE	
Load capacity	kg		5 000
Pulling capacity	kg		12 000
Number of castors	Pieces		4
Castor dimensions	Ø x l	mm	140 x 59
Height		mm	180
Supporting surface of turnable	Ø C	mm	50
Dimensions	L1 x B1	mm	170
Weight without battery + controller	kg		975 x 900
Weight battery + box	kg		164,5
Weight charger	kg		45
Speed	m/min		2
Operational time	h		10
Operating mode in acc. with VDE 0530			4-5
Battery and charger	Pieces		51
Remote control, charger and belt with holder	Pieces		1 x
Remote control, charger and belt with holder	Stück		1 x

ORDER NO.

■ 22 005 210-6 HUB



Retracted turnable



Extended turnable

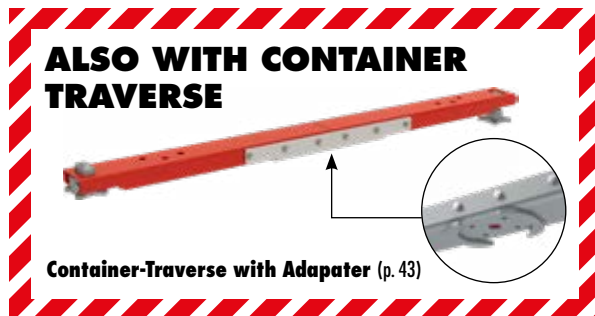

JLA-e 15/30 G facelift with stroke and high-performance battery



30 t

Loads up to

TYPE		■ JLA-E 15/30 G WITH STROKE	
Load capacity	kg		15 000
Pulling capacity	kg		30 000
Number of castors	Pieces		16
Castor dimensions	Ø x l	mm	140 x 59
Height		mm	200
Supporting surface of turnable	Ø C	mm	50
Dimensions	L1 x B1	mm	215
Weight without battery + controller	kg		1 050 x 1 215
Weight battery + box	kg		257,5
Weight charger	kg		45
Speed	m/min		2
Operational time	h		6,5
Operating mode in acc. with VDE 0530			4-5
Battery and charger	Pieces		S3 60%
Remote control, charger and belt with holder	Pieces		1 x
Remote control, charger and belt with holder	Stück		1 x

ORDER NO.

■ 22 015 210-G HUB

USEFUL ACCESSORIES

For electric-powered transport trolleys

POWER SUPPLY

- Suitable for JLA-e 5/12 G und 15/30 G
- Cable length to the JLA-e: 10 m
- Cable length to the network: 2 m
- Output voltage DC: 48 V nominal
- Input voltage AC: 100-240 V
- Mains frequency: 50-60 Hz
- Temperature range: -25° C up to +70° c operational
- Mounted on castors with push handle and cable holder.
- Weight: 18 kg



POWER SUPPLIES

POWER SUPPLY

		JLA-e 5/12 G & JLA-e 15/30 G	
Dimensions	mm	210 x 316 x 394	
Weight	kg	18	

ORDER NO.

23 900 003-B



TROLLEYS ELECTRIC-POWERED

FAST CHARGER

BATTERY EXTENSION CABLE SET

DRIVE WHEEL

		JLA-e 5/12 G JLA-e 15/30 G JLA-e 25/50 H	JLA-e 5/12 G JLA-e 15/30 G JLA-e 25/50 H	JLA-e 5/12 G JLA-e 15/30 G JLA-e 25/50 H	JLA-e 5/12 G JLA-e 15/30 G	JLA-e 25/50 H
Dimensions	mm	-	5 000 long	10 000 long	140 x 118 x 35	200 x 83 x 70

ORDER NO.

23 050 556-E

93 151 003-B5

93 151 003-B10

93 050 157-V

93 050 521-V



TRANSPORT BOXES **TRANSPORT BOX JLA-E**

		JLA-e 5/12 G	JLA-e 15/30 G
Dimensions	mm	1320 x 880 x 760	1320 x 880 x 760
Weight	kg	190	190

ORDER NO. **93 005 001-S** **93 015 001-S**

i
Our transport boxes can be moved with pallet trucks and forklifts!



TRANSPORT BOXES **TRANSPORT BOX JLA-E FOR STROKE**

		JLA-e 5/12 G for stroke	JLA-e 15/30 G for stroke
Dimensions	mm	1320 x 1100 x 760	1320 x 1100 x 760
Weight	kg	205	205

ORDER NO. **93 005 001-H** **93 015 001-H**



TRANSPORT BOXES **TRANSPORT BOX JLA-E 25/50 H**

		JLA-e 25/50 H
Dimensions	mm	1 940 x 1 268 x 600
Weight	kg	355

ORDER NO. **93 200 125-H**

TROLLEY

AIR-POWERED

For loads up to 30 metric tons, height 180 mm

i DESCRIPTION

- Ecofriendly, uses only compressed air.
- Spare a towing vehicle.
- Low maintenance propulsion system.
- No need to charge any batteries.
- 360° maneuverable.
- Compatible with G-series transport trolleys (page 32-33).
- All hoses are detachable for compact and easy transport.
- Quick set up. Connect air supply hose and go.
- Requires standard shop air connection with 8 bar (116 psi) and air volume of 1500 L/ min (25 L/ s) or (53 SCFM).
- Continuously adjustable by adjusting the working pressure.
- Length of the air hose: 4 m
- Model JLA-p 15 / 30 G includes the trolley and remote control unit.
- Two air motors are independently controllable by two joysticks.
- Maneuverability: Forward, reverse, in place turning.
- Higher capacities available on request.



Loads up to		15 t	
TYPE		■ JLA-P 15 / 30 G	
Load capacity	kg	15 000	
Pulling capacity	kg	30 000	
Number of castors	Pieces	16	
Castor dimensions	Ø x l mm	140 x 59	
Height	mm	180	
Supporting surface per cassette	Ø C mm	215	
Dimensions	L1 x B1 mm	650 x 1 000	
Weight without control box	kg	175	
Air consumption	L/sec.	25	
Required air pressure	bar	8	
ORDER NO.		■ 22 150 140-V	

TROLLEY SETS

AIR-POWERED



i TROLLEY SETS

Set 2 includes:

- JLA-p 15/30 G includes control unit
- Hose cart complete with hose reel
- 30 m air supply hose with Ø 19 mm
- 1 Liter oil for pneumatic motors
- 400 ml chain spray (not overseas)



Underside view of JLA-p trolley

Set 3 additionally includes:

- Transport trolley JFB 15 G (see page 32)



JLA-p Set in action



JLA SETS

TYPE		JLA-P SET 2	JLA-P SET 3
JLA-p incl. control box		1 x	1 x
Hose length/diameter		30 m/19 mm	30 m/19 mm
Cart + oil + chain spray		1 x	1 x
JFB 15 G		-	1 x
Weight	kg	175	338
ORDER NO.		22 150 140-VP2	22 150 140-VP3

MOVING **IN FORMATION.**

Intelligent. Precise. Safe.



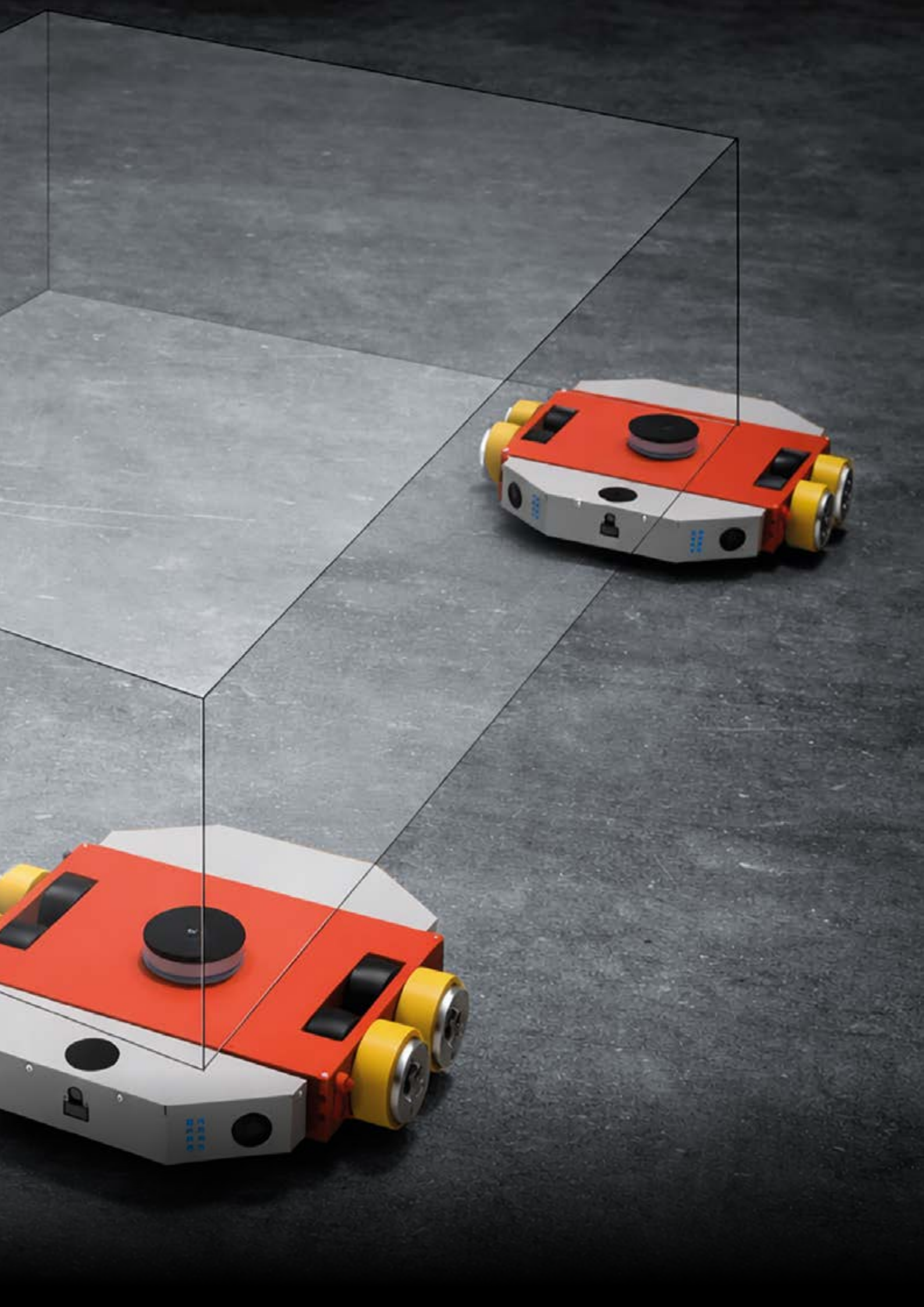

» JLA-eForm



ELECTRIC-POWERED TRANSPORT TROLLEYS IN FORMATION

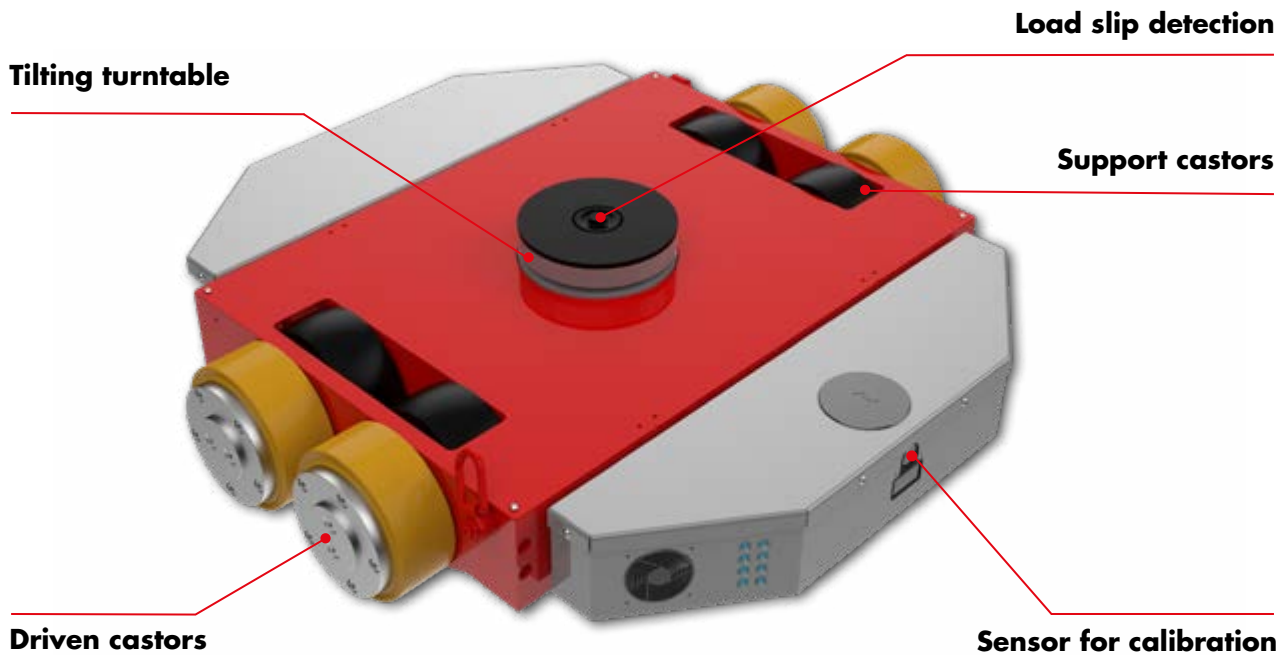

Video
JLA-eForm:



TYPE		■ JLA-EFORM 15/30 H	
Load capacity	kg		15 000
Pulling capacity	kg		30 000
Number of castors	Pieces		8
Castor dimensions	Ø x l	mm	200 x 78
Height		mm	240
Supporting surface of turntable	Ø C	mm	215
Dimensions	L1 x B1	mm	1090 x 1060
Weight	kg		395
Weight charger	kg		2
Battery type			Li-Ion
Speed		m/min	9
Operational time		h	4-5

i DESCRIPTION

■ Developed in close collaboration with FORMIC Transport-systeme GmbH, the JLA-eForm combines decades of heavy-load transport expertise with cutting-edge drive technology.

■ The transport modules can be positioned flexibly under the load – depending on the center of gravity and available space – allowing optimal adaptation to a wide range of transport requirements.

■ The intuitive touchscreen control enables convenient and precise operation of all units. Depending on the application, up to three vehicles can be controlled simultaneously via a single remote.

SAFETY SENSOR SYSTEM

A sensor for detecting load shifts enhances safety.

OMNIDIRECTIONAL MANEUVERABILITY

The vehicles can move in all directions and are suitable for use in very confined spaces.

FLEXIBLE POSITIONING

The transport trolleys can be positioned flexibly beneath the load, depending on the center of gravity and the available space.



PRECISE POSITIONING

Accurate and sensitive positioning of the transport trolleys is possible.

ROTATION AROUND ANY PIVOT POINT.

The load can be rotated around any pivot point.

INTUITIVE TOUCHSCREEN CONTROL

A large touchscreen on the remote control enables comfortable and simultaneous control of up to three devices.



ACCESSORIES FOR FORKLIFTS

Transport dolly hitch, steering traverse & forklift clamps

i DESCRIPTION

■ **FORKLIFT HITCH** for pushing and pulling loads. Includes lashing chain to secure to forklift truck. Suitable for all JUNG trolleys outfitted with a towing eye.

■ 3 metric tons traction force.*

■ Simply place on forklift forks, secure with lashing chain and go.

■ Easy maneuverability.

■ Capable of moving loads forward and in reverse.



TYPE		■ JRH 3	
Push/Pull force	kg	3 000	
Dimensions L x W x H	L x W x H mm	425 x 590 x 325	
Hitch pin	Ø mm	40	
For forks	max. mm	90 x 170	
Fork separation	min. mm	240	
Weight	kg	35	

ORDER NO. ■ 13 303 000-B

*Equivalent to 60 tonnes of transport weight with JUNG landing gear on level ground.

i DESCRIPTION

■ **Forklift turntable** for maneuvering heavy loads with a forklift truck.

■ Thrust bearing supported turntable with anti-slip load pad.

■ Simply place on the forklift forks and go.

■ Reversed side equipped with anti-slip pads.

■ Usable as steerable support for 3 or 15 t



TYPE		■ JLT 3		■ JLT 15	
Load capacity	kg	3 000		15 000	
Dimensions	L x W x H mm	550 x 240 x 100		550 x 300 x 174	
Supporting surface of turntable	Ø mm	150		250	
For forks	max. mm	180		180	
Fork separation	min. mm	200		200	
Weight	kg	18		43	

ORDER NO. ■ 13 203 000-V

■ 13 215 000-V

i DESCRIPTION

■ **Set of forklift clamps with tie-down straps** for binding and securing.

■ Secure valuable and unstable loads against slipping.

■ Each set includes 2 screw type fork clamps, 2 eye type fork clamps and 2 tie-down straps.

■ Simply attach the screw type fork clamps to the forks behind the load.

■ More safety for movement of top heavy loads.

■ Slide eye type fork clamps onto the tips of the forks and strap load in between for safe transport.



Secure loads with forklift clamps and tension belts

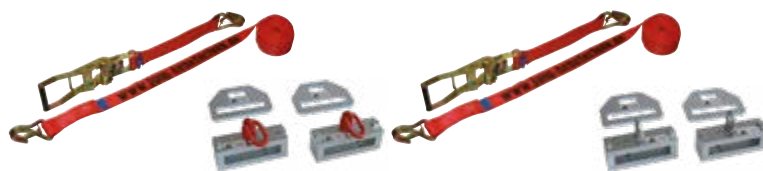
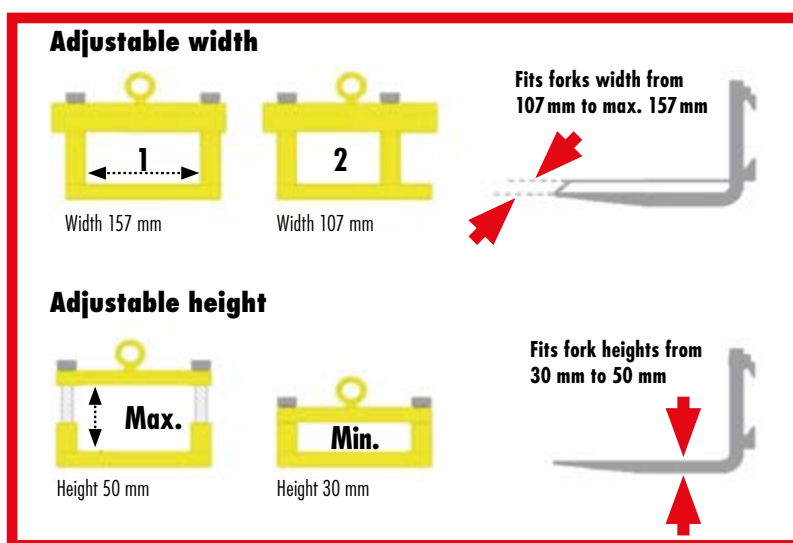

TYPE		JGK-A	JGK-R
Version		with SWIVEL eye bolts	with FIXED eye bolts
Features		turnable	fixed
Forks width	mm	107 - 157	107 - 157
Forks height	mm	30 - 50	30 - 50
Length of tie-down straps	mm	5000	5000
Bind capacity	daN	400	400
Weight	kg	19	18

ORDER NO. ■ 25 090 401-B ■ 25 090 451-B

QUICKLY
TRANSPORTED.



JUNG

HYDRO-TRANSPORTER



For loads up to 3,8 metric tons

i DESCRIPTION

■ Hydro transporters are simple and very safe to use. The two halves of the hydro transporter are fastened to the sides of the device or goods to be transported (cabinets, safes, machines, boxes, etc.) using the lashing strap, creating a single transport unit.

■ After pumping up the movable part of the transporter on both sides the load is lifted and ready for moving.

■ Both transport units are easy to transport together.

■ Scope of delivery: 2 transport units, 2 connecting belts (5m)

■ Steering can be done by the top link bars on each unit, connected with the big wheels equipped with ball bearings. The linkage guarantees that the wheels are always in parallel direction.

■ High lifting height: 180 mm

■ The load capacity specifications refer to a maximum speed of 2 km/h.



Boxes, safes or machines - quick and easy to handle with the Hydro-Transporter!



Loads up to		1,8 t	3 t	3,8 t
TYPE		JHT 18 S	JHT 30 S	JHT 38 S
Load capacity	kg	1 800	3 000	3 800
Lift	mm	180	180	180
Height	H mm	1 010	1 080	1 080
Length	B mm	540	585	640
Belt length	mm	5 000	5 000	5 000
Wheel diam. Ø	mm	150	200	200
Weight	kg	82	103	107

ORDER NO.	JHT 18 S	JHT 30 S	JHT 38 S
	30 181 002-H	30 301 001-H	30 351 002-H

NICKEL-PLATED STEEL EQUIPMENT & CUSTOMISED SOLUTIONS

NICKEL-PLATED STEEL EQUIPMENT

- Better surface protection in case of collision damage (no chipping of the topcoat).
- Improved protection against corrosion.
- Good application in sensitive environments such as clean rooms.
- Surface protection, solvent resistance.



JH 6 G plus

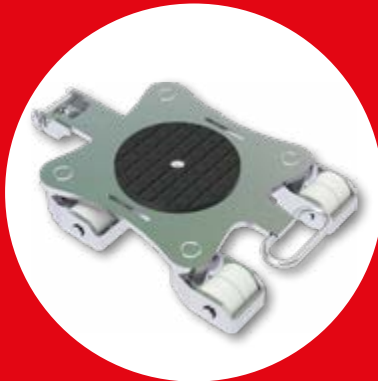

JKB 3

CUSTOMISED SOLUTIONS



Towing devices

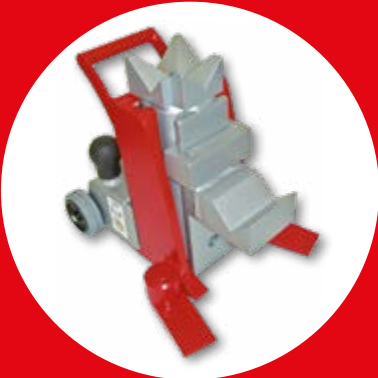

Special types of lifting toes/Special adapter for jacks

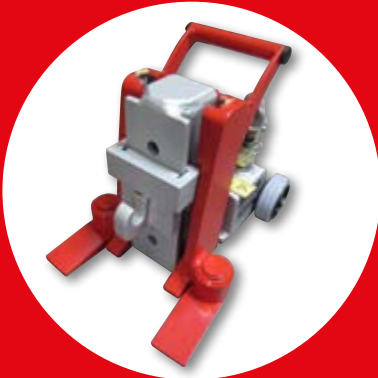

**Customised transport set
JLF & JKB**



Special Construction JLB 20 G

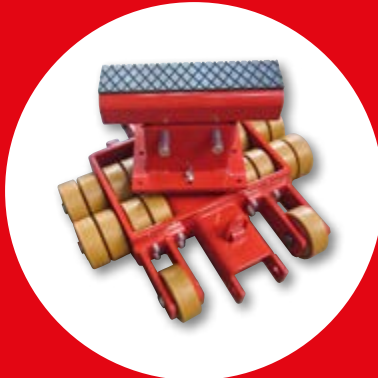

CATALOG OVERVIEW

Visit us on:



Tugger trains for intralogistics



Support technology/ Ground protection



Industrial hydraulics BVA



Leveling castors



Lifting bags



Custom solution needed?

We solve uncommon lifting and transport problems by custom solutions - safe, fast and cost effective. Please do not hesitate to contact us!

Design, manufacturing, consulting, sales and service:

JUNG Hebe- und Transporttechnik GmbH

F +49 (0)7151 30393-0
info@jung-hebetechnik.de
Biegelwiesenstraße 22
D-71334 Waiblingen
jung-hebetechnik.de

Unser Logo und der Name JUNG sind in der EU, in den USA und in China unter folgenden Nummern geschützt:

EU: Logo Nr. 005878897, Name Nr. 005878806

USA: Logo Reg. Nr. 3,713,850, Name Reg. Nr. 3,697,526

China: Logo Nr. 14081450A, Name Nr. 14081449A

Technische Änderungen, die der Verbesserung von Funktion und Qualität dienen, behalten wir uns vor.

Made in Germany 03.2026 · Printed in Germany

Our logo and brand name „JUNG“ are registered as trademarks in the EU, US and China with register numbers:

EU: logo no. 005878897, name no. 005878806,

USA: logo reg. no. 3,713,850, name reg. no. 3,697,526

China: logo no. 14081450A, name no. 14081449A

We reserve the right to make technical modifications which serve to improve function and quality.

Made in Germany 03.2026 · Printed in Germany

JUNG
JUNG-HEBETECHNIK.DE